

A futuristic, sleek car is shown from a front-three-quarter perspective, driving on a desert road. The car's headlights are glowing with a bright orange light. The background features a vast, flat desert landscape under a sunset sky with soft, warm colors. The car's design is aerodynamic and modern, with a prominent front grille and large, rounded headlights.

 verso studio

Supercraft

La creatività nell'era dell'IA generativa



Jane Goodall nel 1960 scoprì che l'abilità di usare strumenti (e tecniche) non era esclusiva degli esseri umani.

Ciò che ci distingue è la capacità di copiarli e modificarli nel tempo.

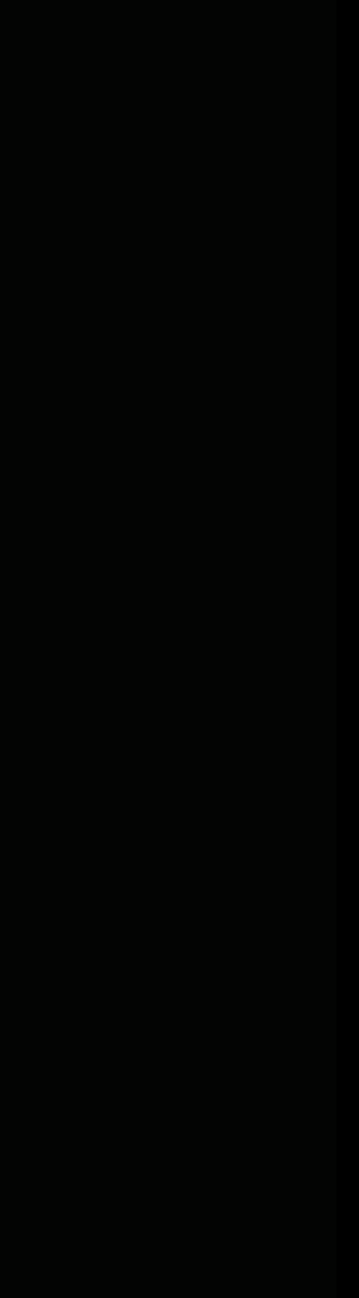

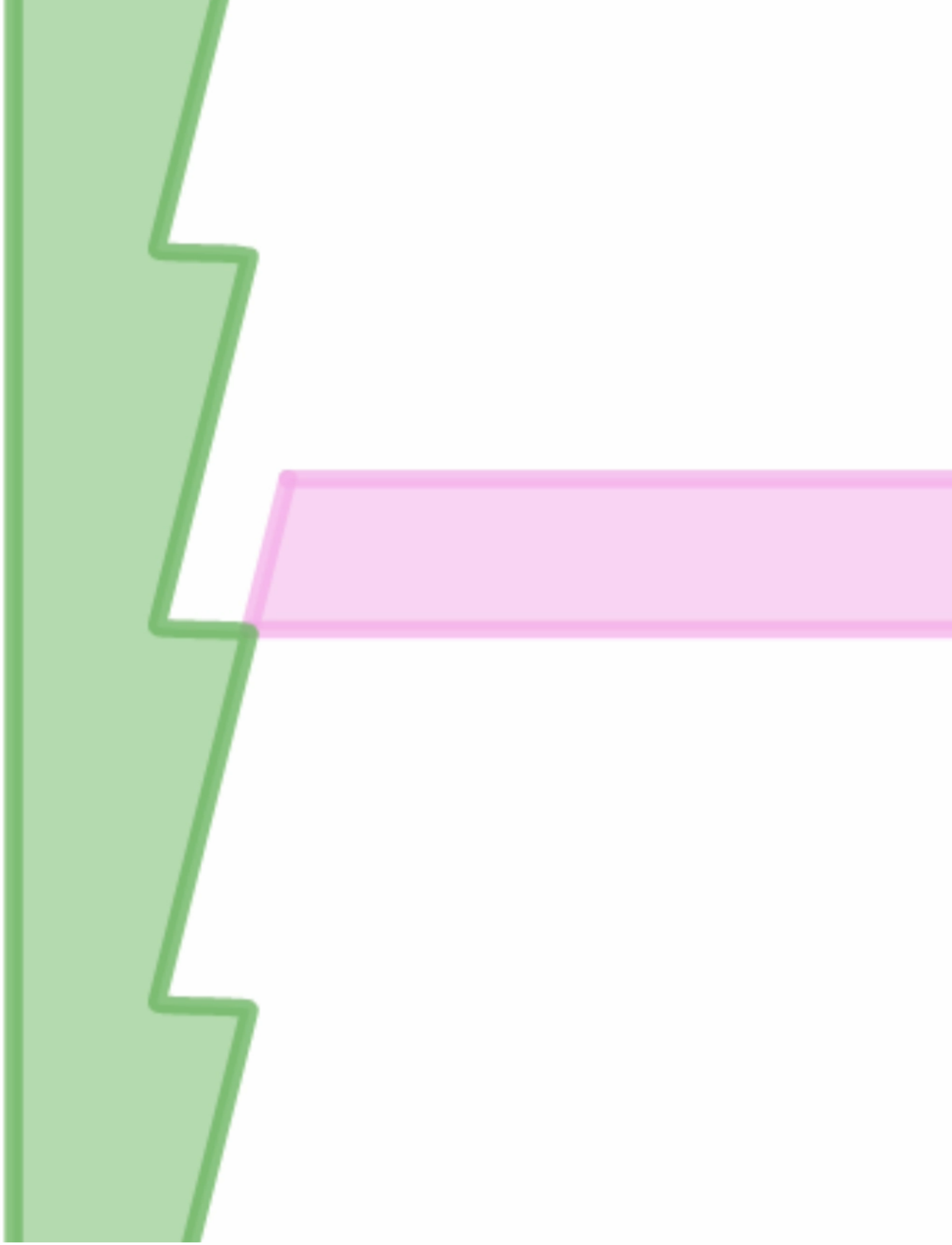

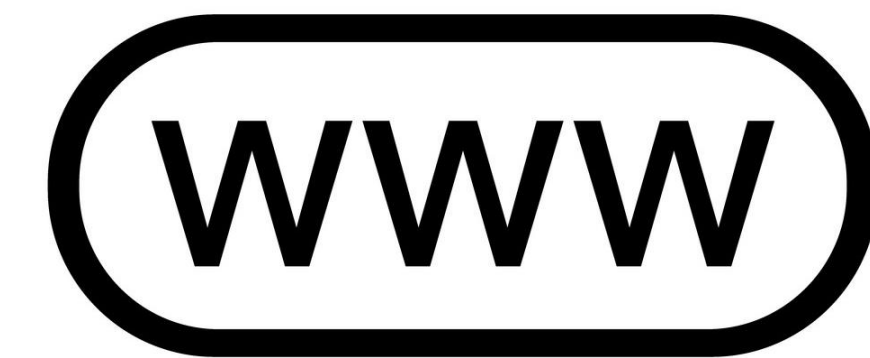

Produzione

Distribuzione



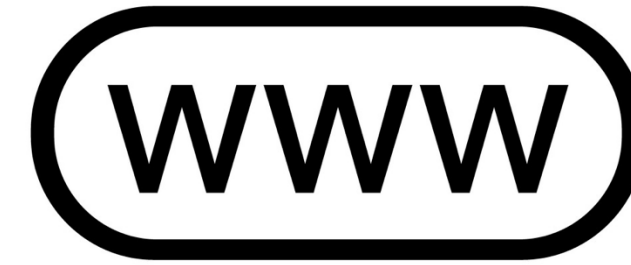

 Google AI

OpenAI

DALL·E



Produzione

Distribuzione

Input

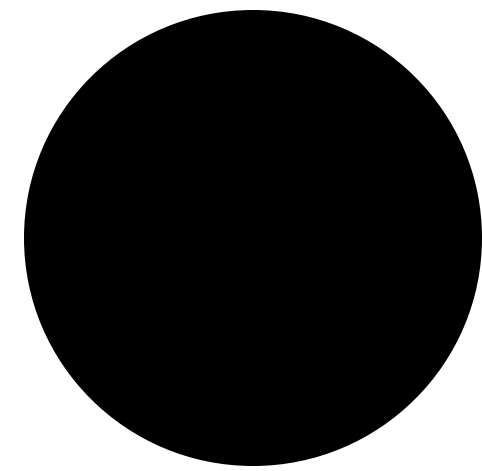

Output

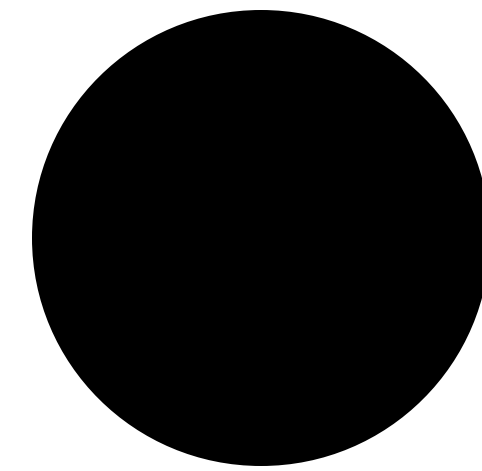

Input

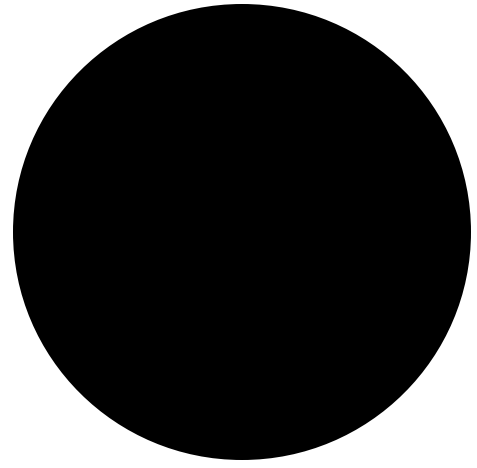

Output

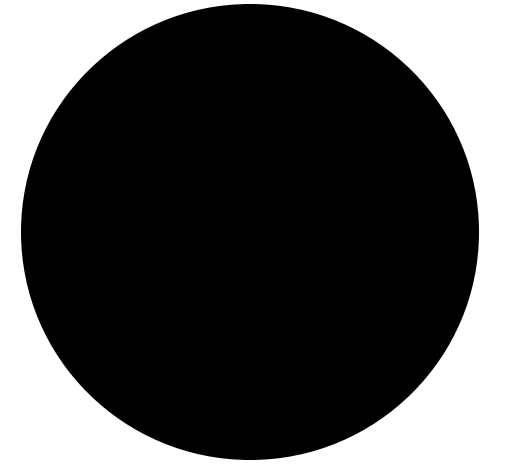

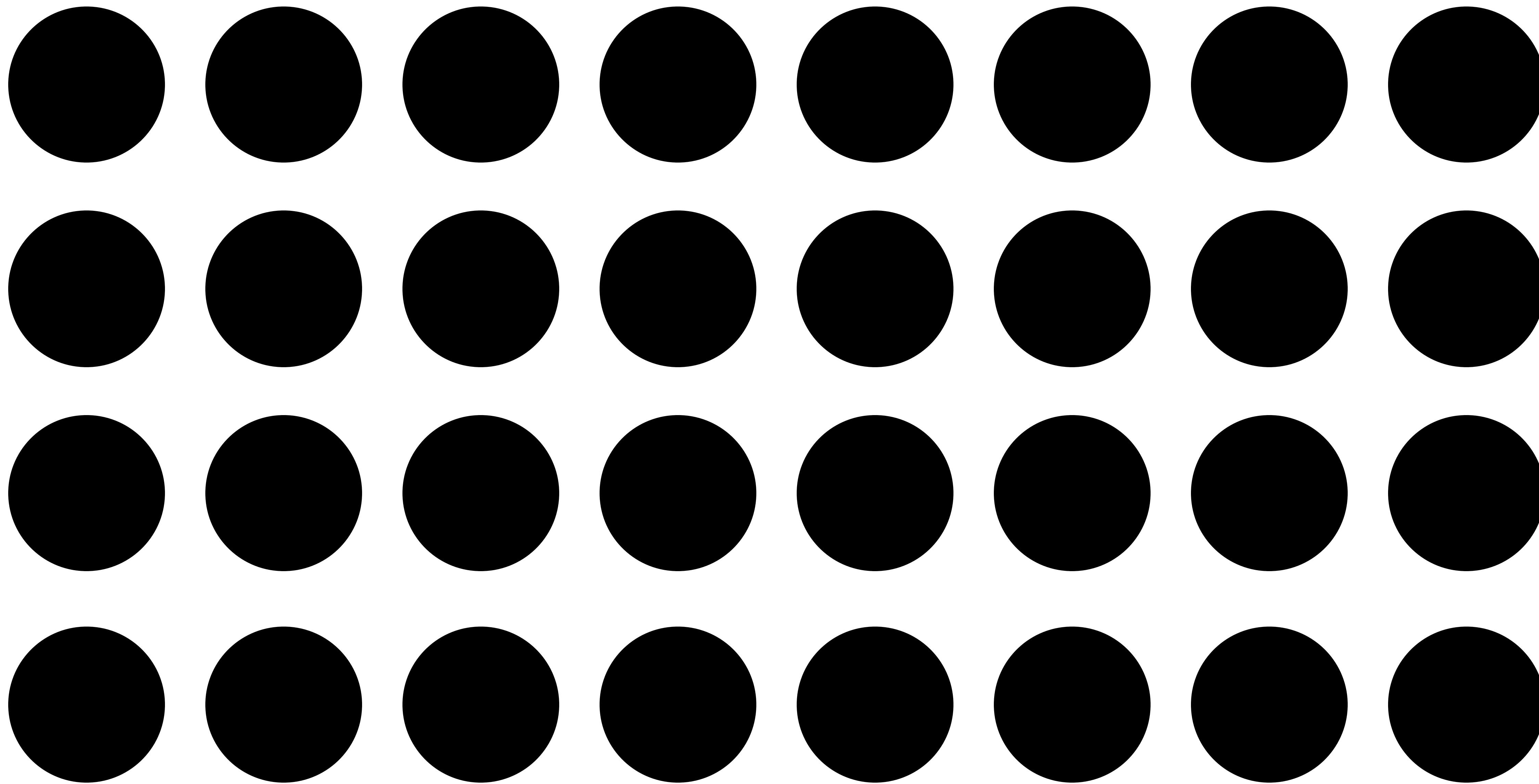

Model

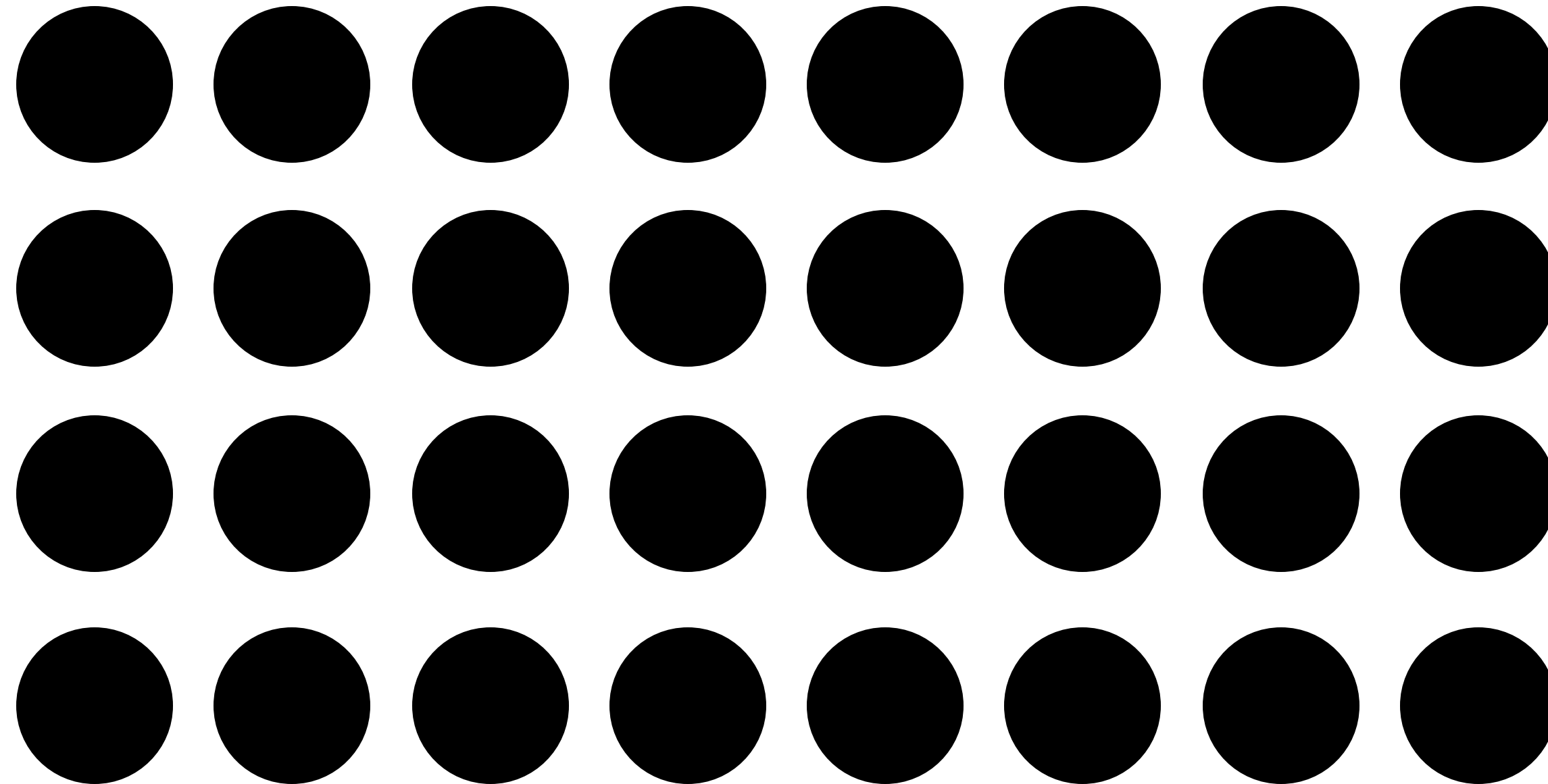

Model

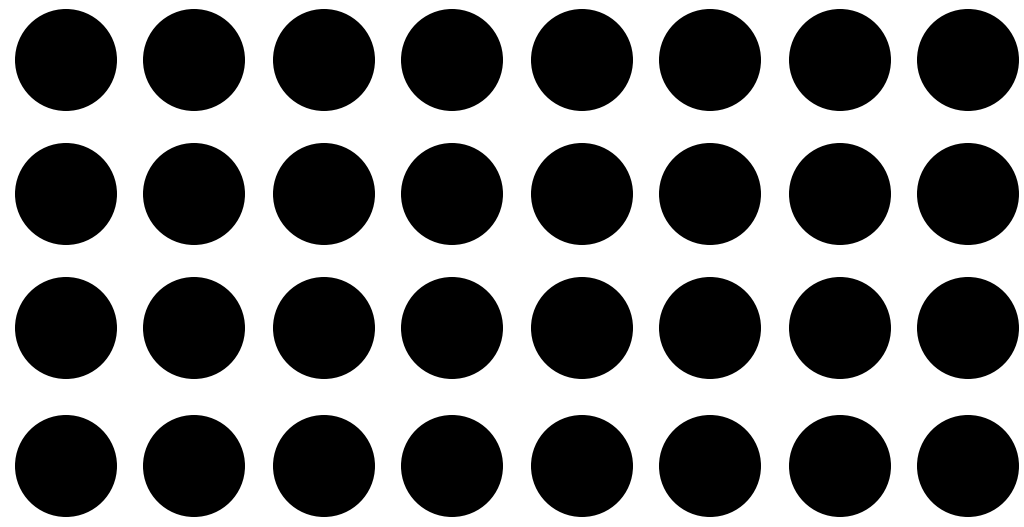

Model

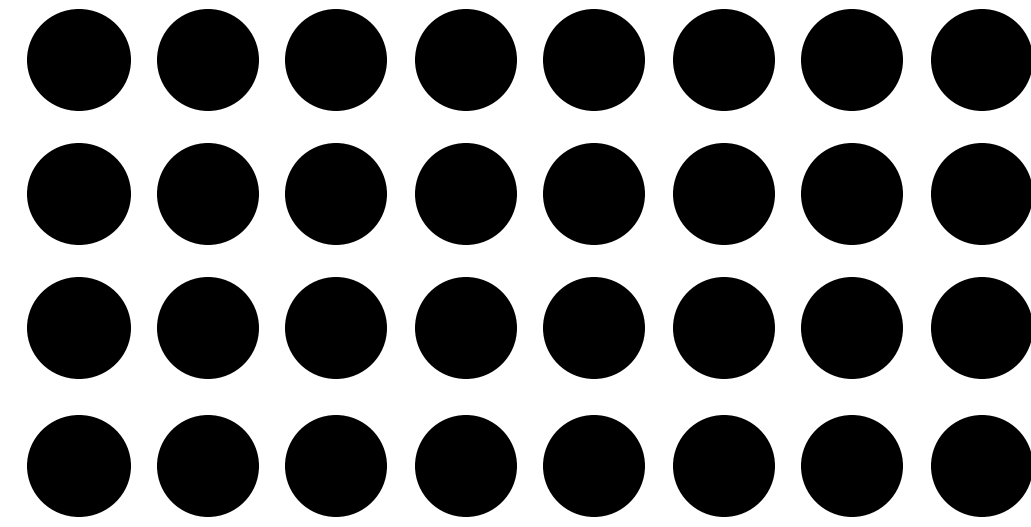

Model

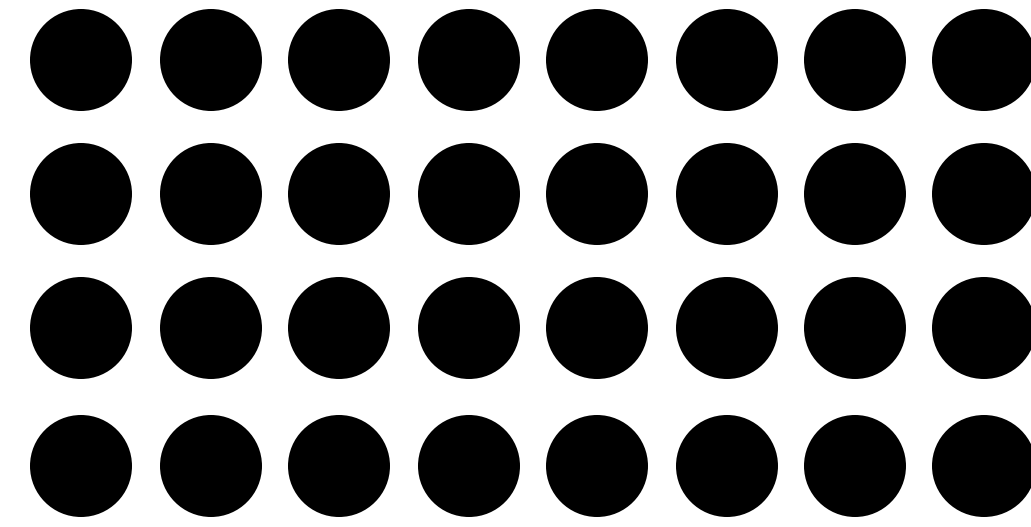

Model

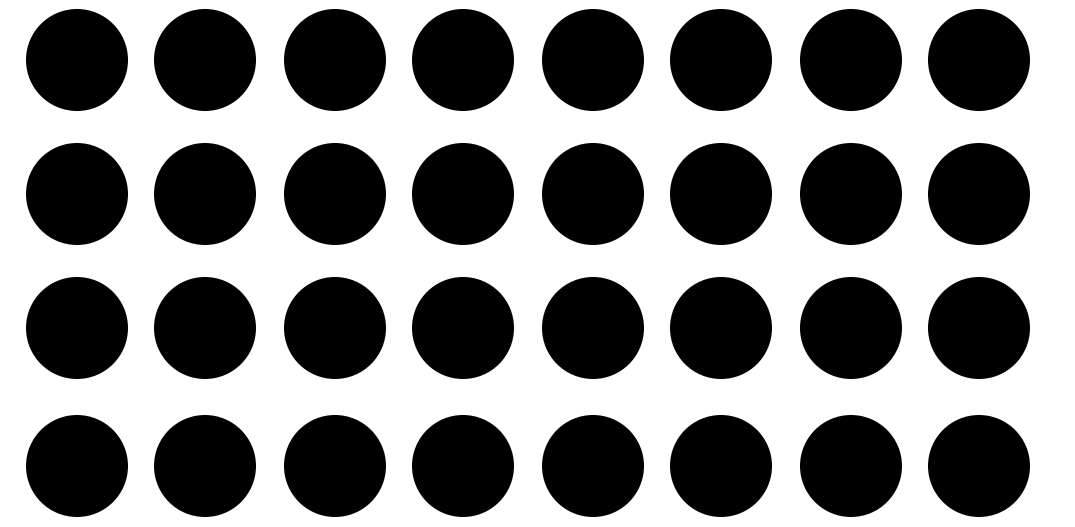

Model

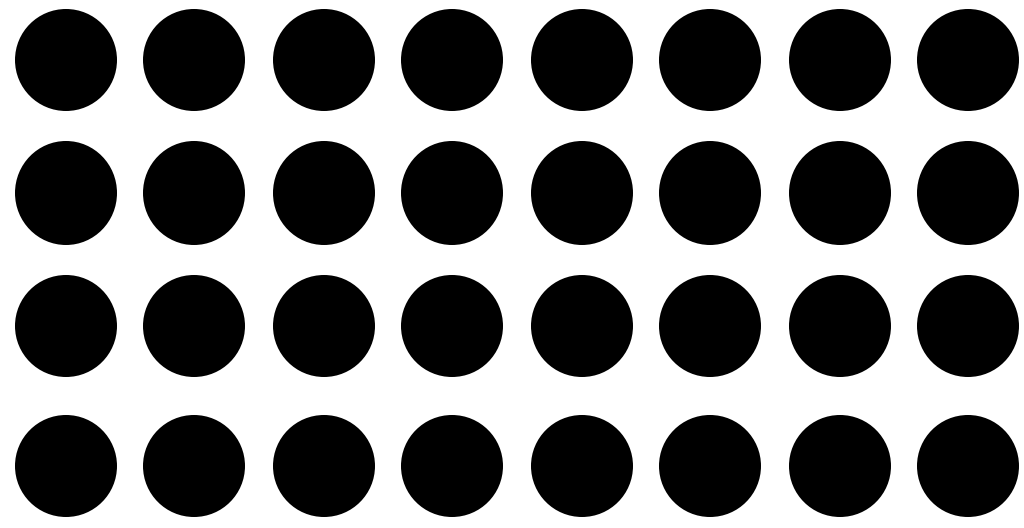

Model

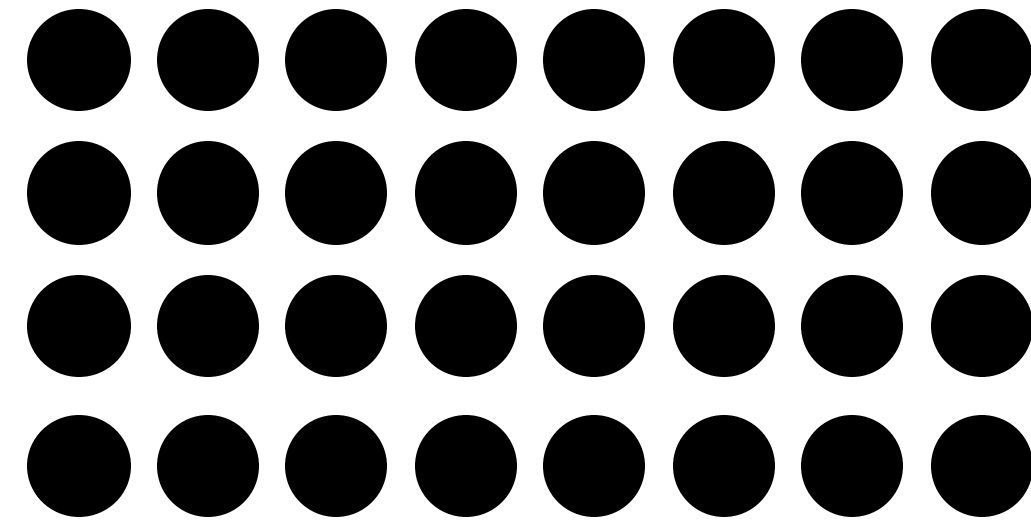

Model

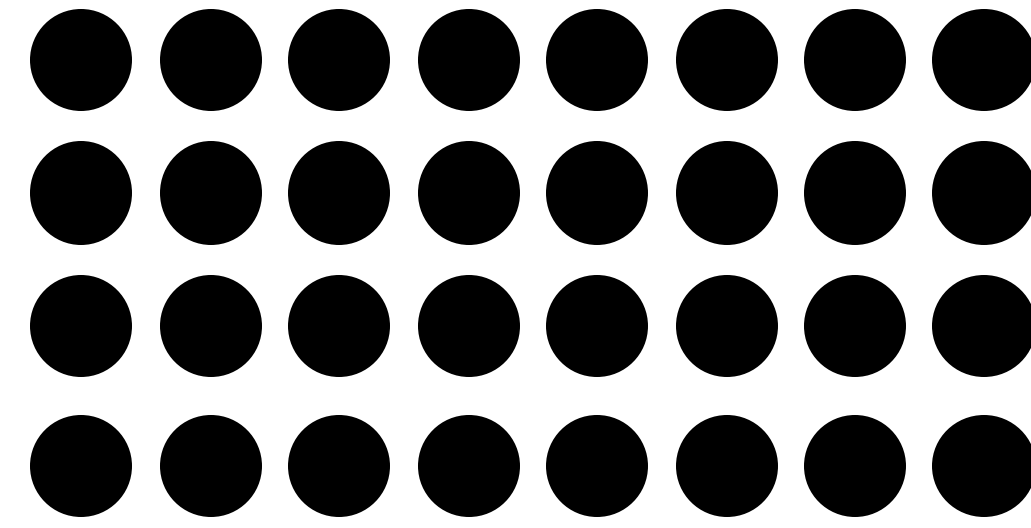

Model

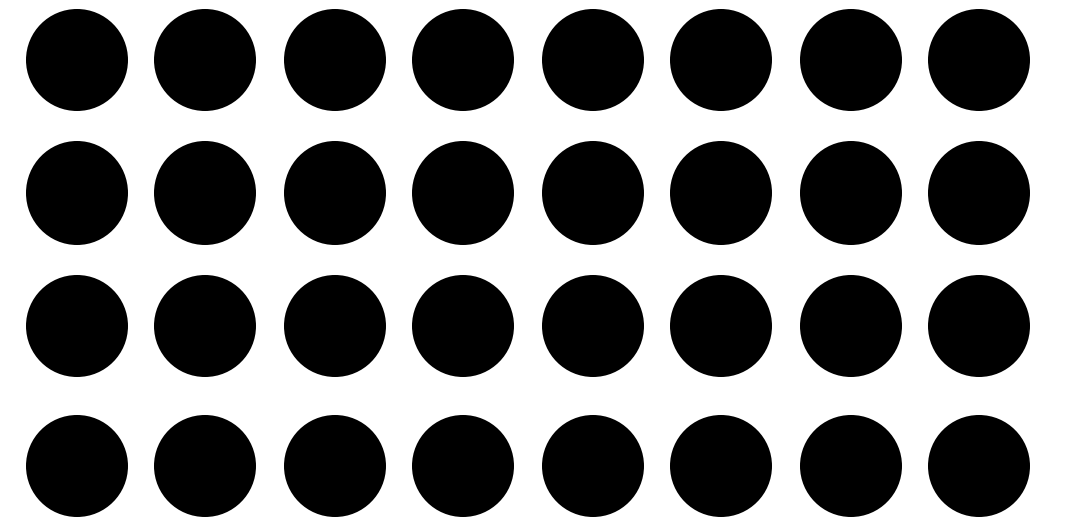

Model

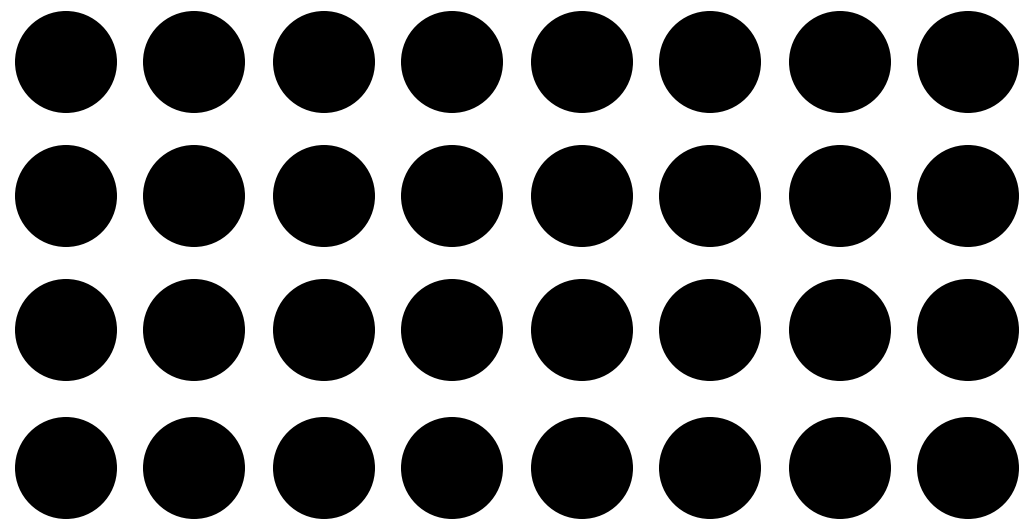

Model

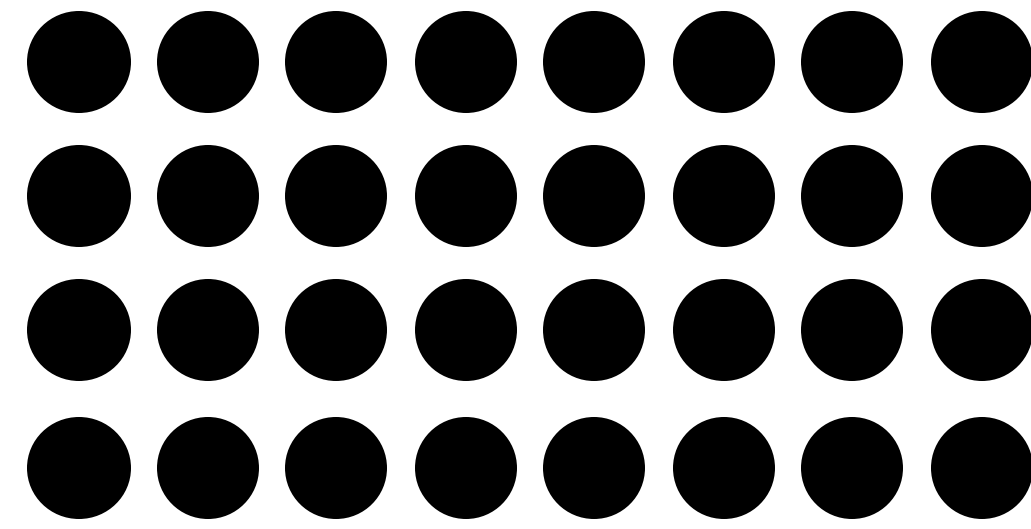

Model

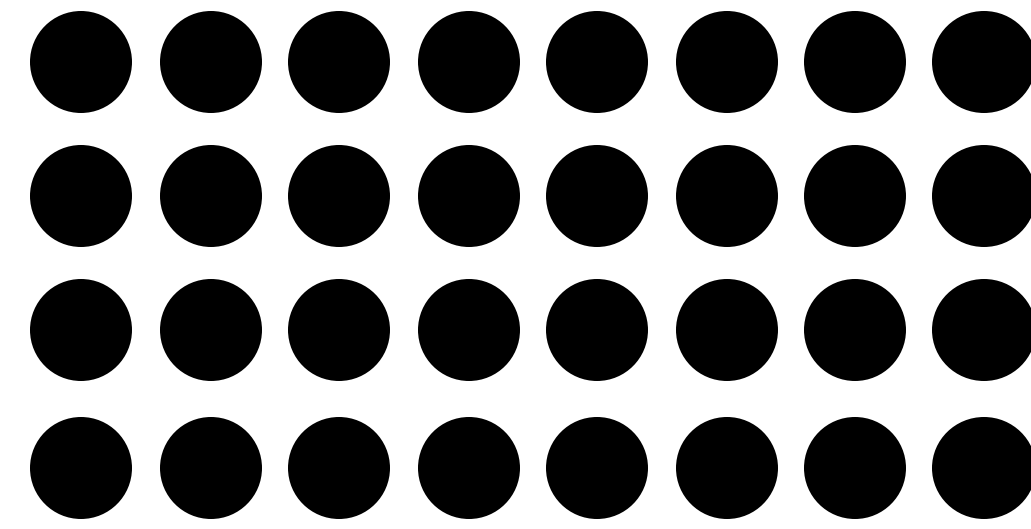

Model

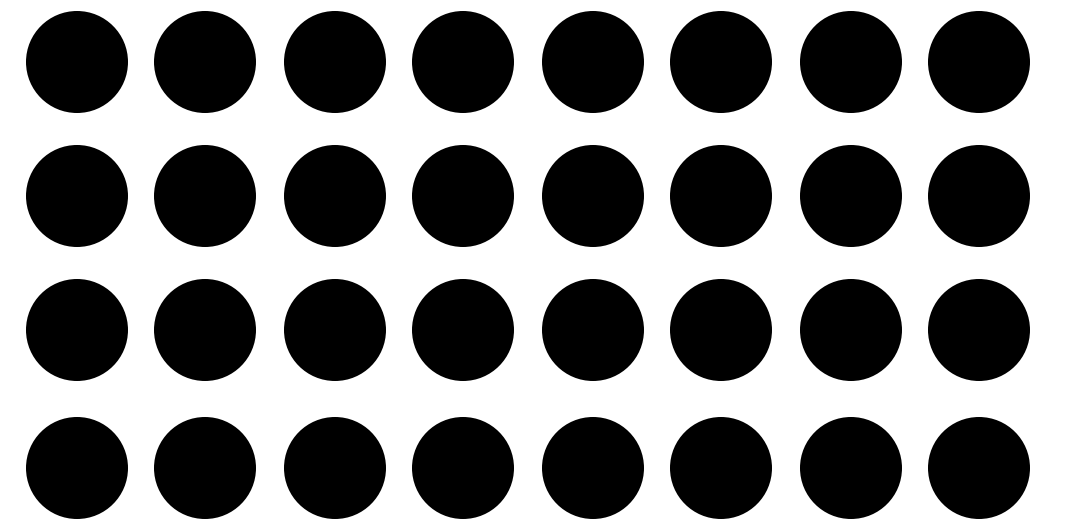

Macchine Creative

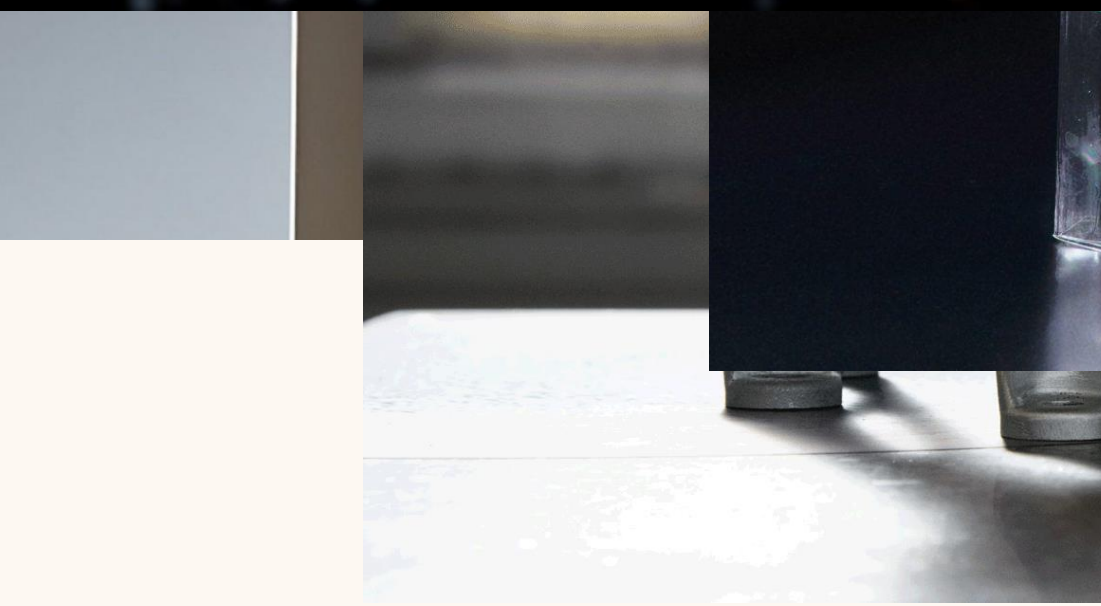

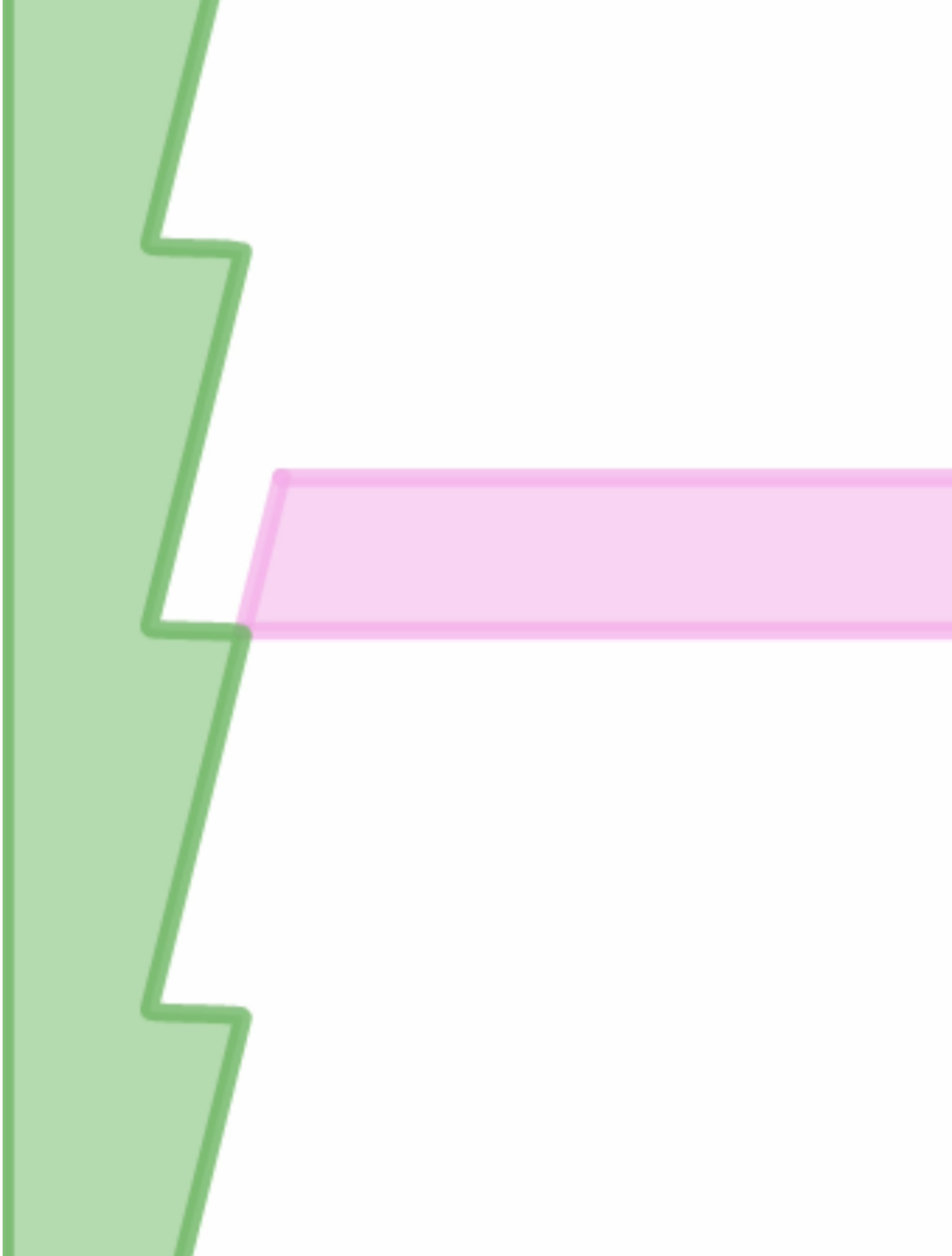



**Dove si colloca la
creatività umana?**



[Louis Daguerre: Boulevard du Temple](#)



[Jean-Léon Gérôme](#)



+ Chatta con ChatGPT



Selection ^

Preview

Topics

- Interior Architecture
- Furious 7
- Porsche 911

url url



<https://generations.krea.ai/images/6a765469-205b-...>

generation_id text
6a765469-205b-411e-b11e-02f6be16f3ff

id_text
03a3d72f-d048-4c4d-9172-005d23ef2566

prompt text
Classicism painting of a neon hypercar in the italian count

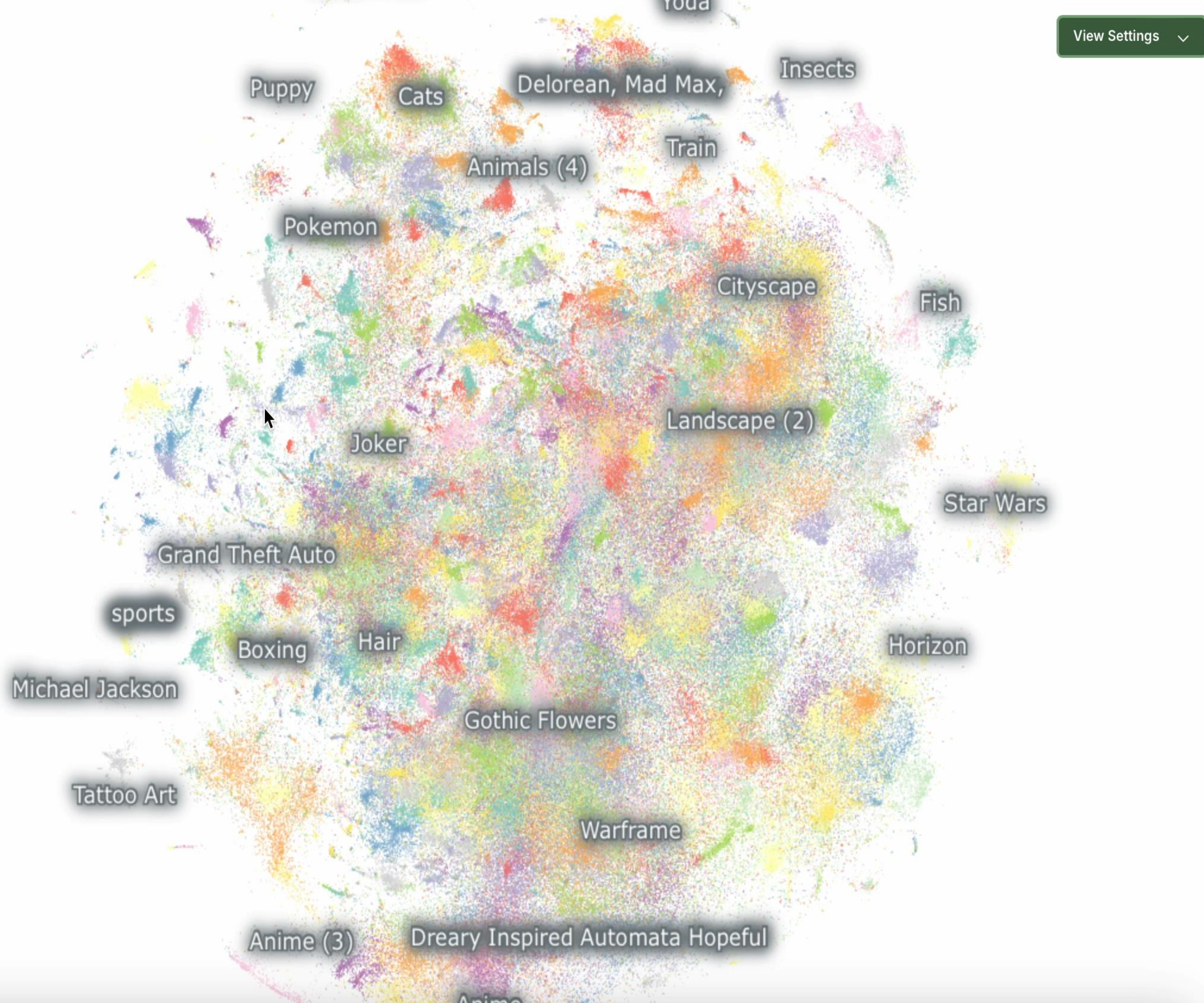

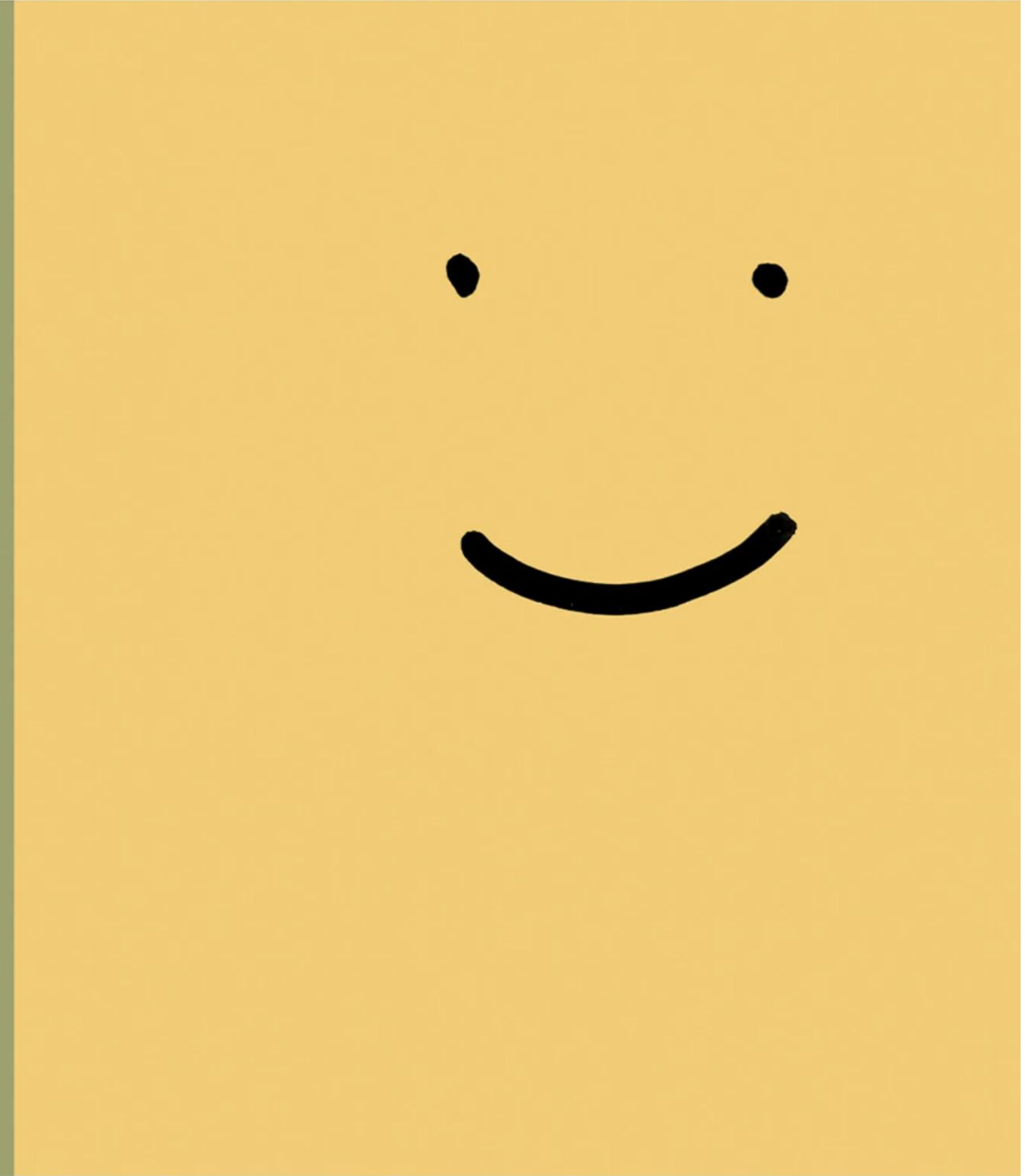
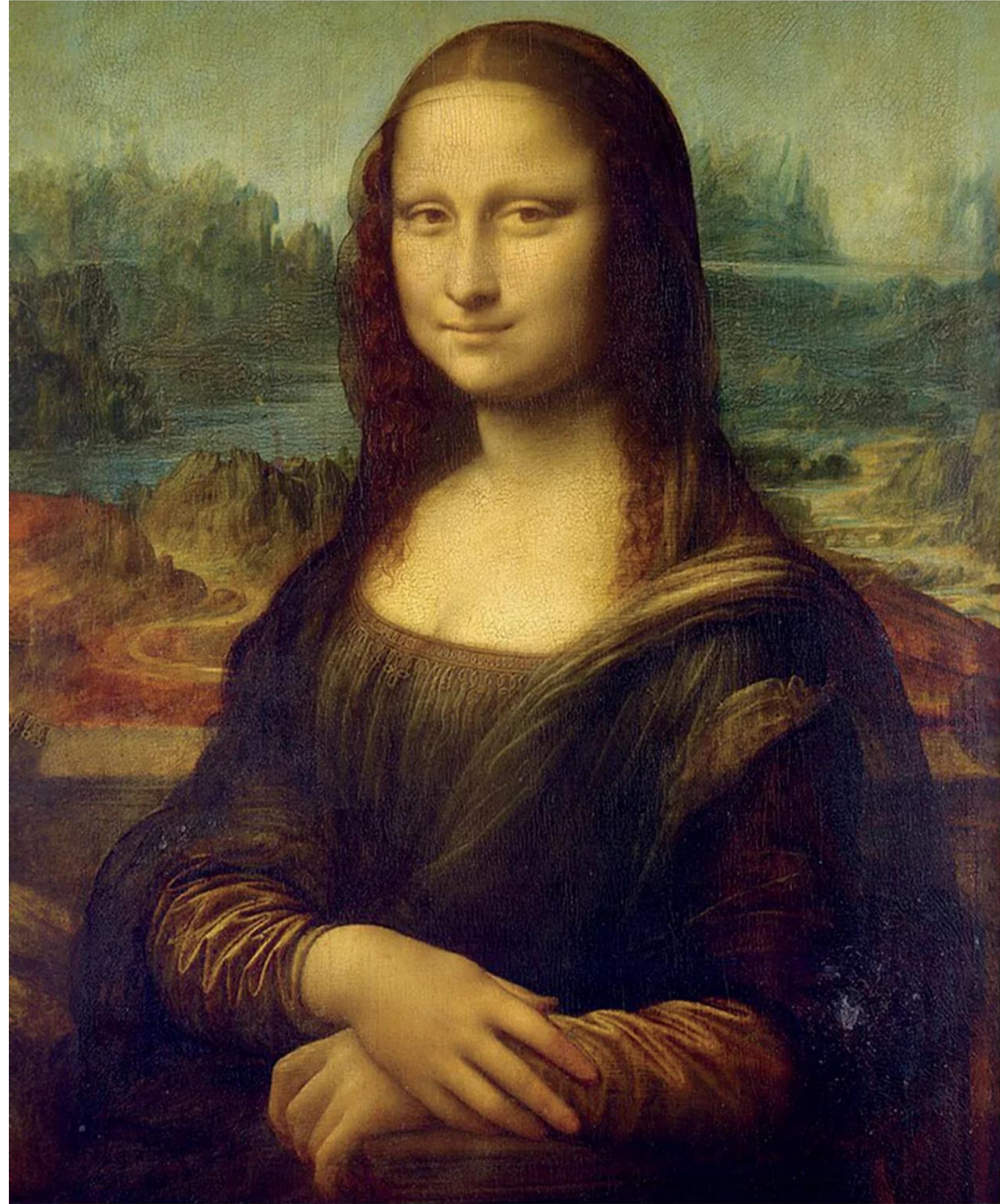

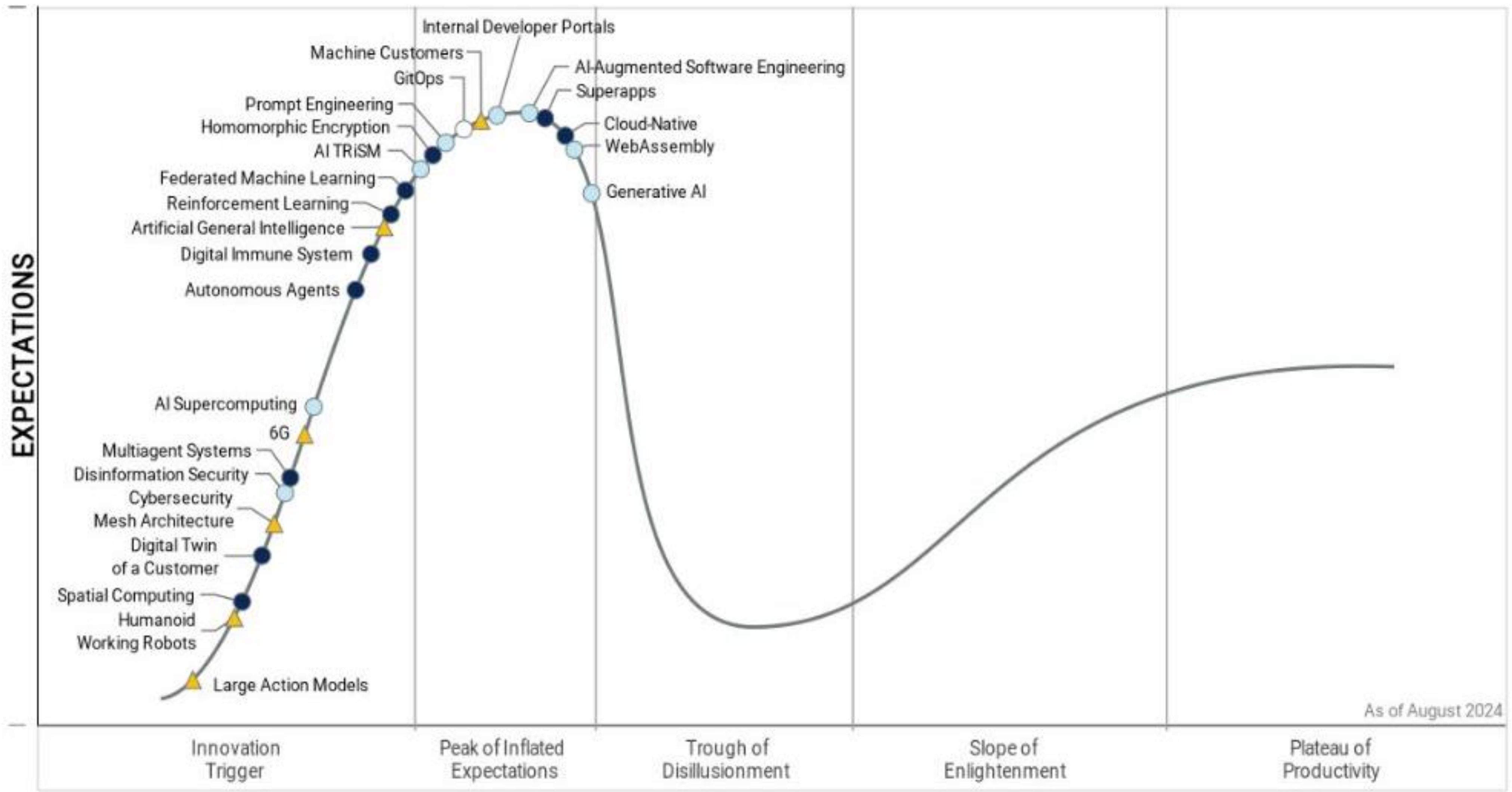

Last 2 years

Next 5 years

Agent A

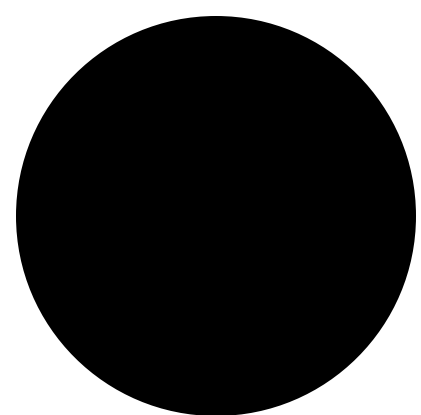

Agent A

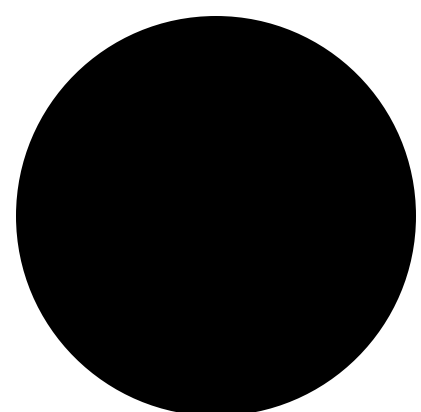

Agent B

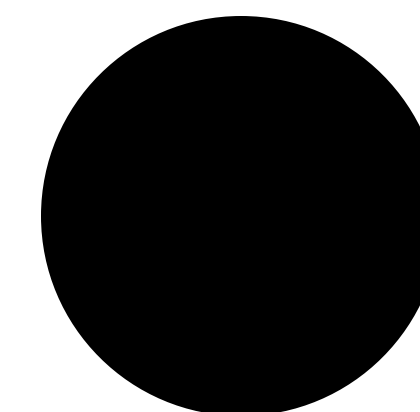

Agent C

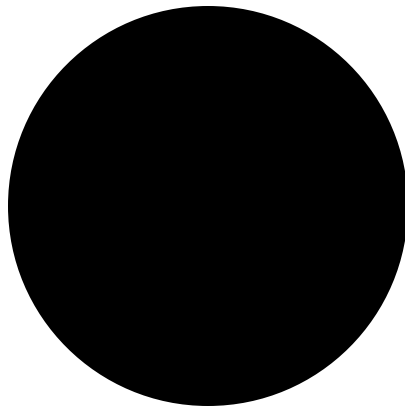

Agent A

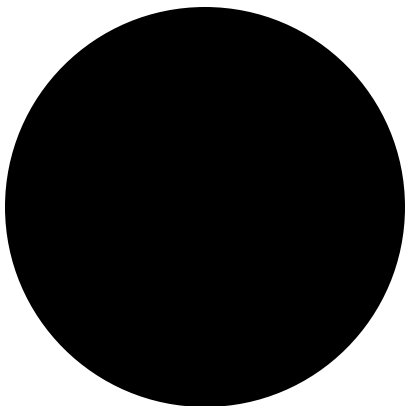

Agent B

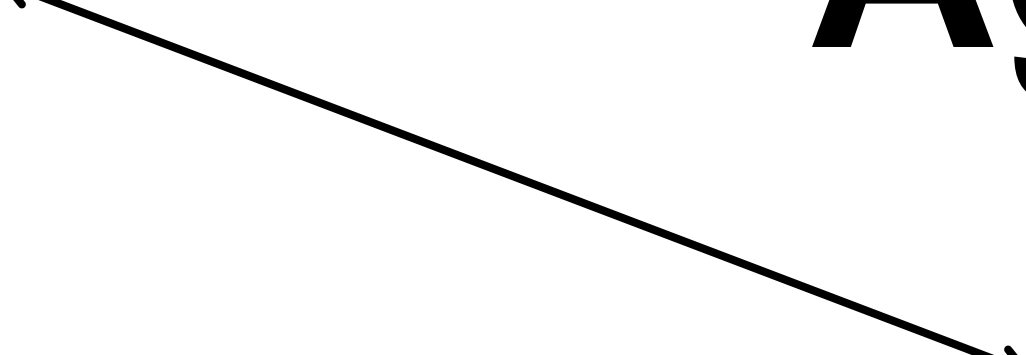
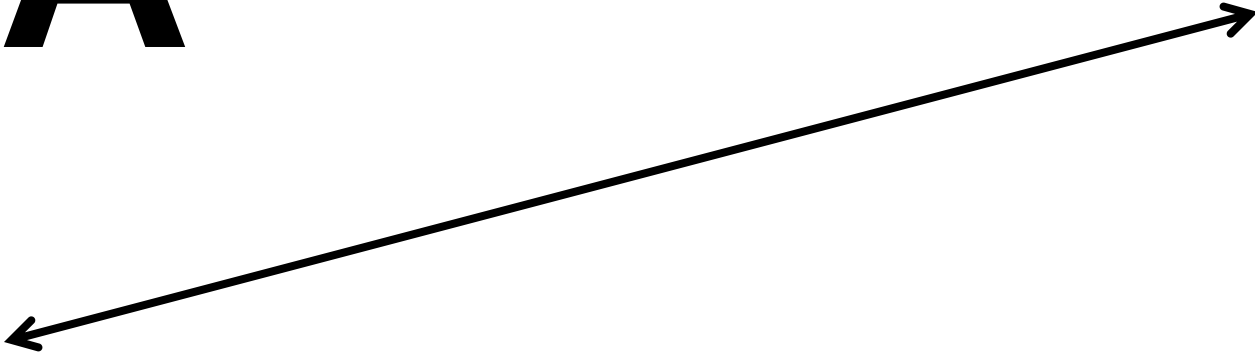
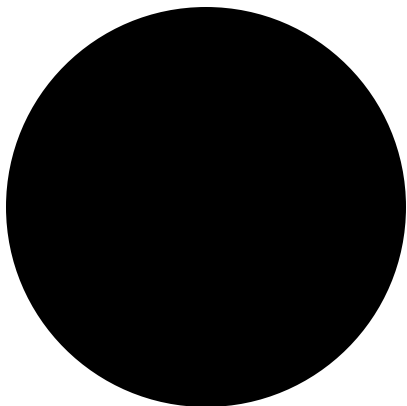

Agent B

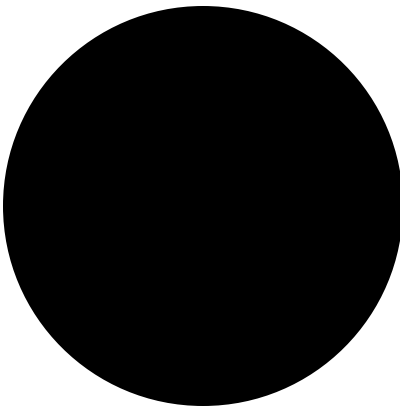

Agent A

Agent B

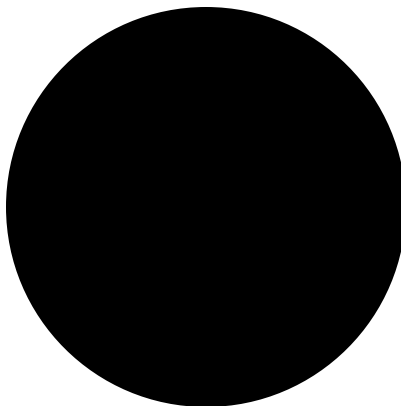
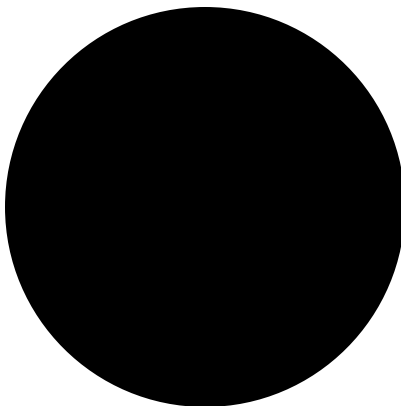

Agent D

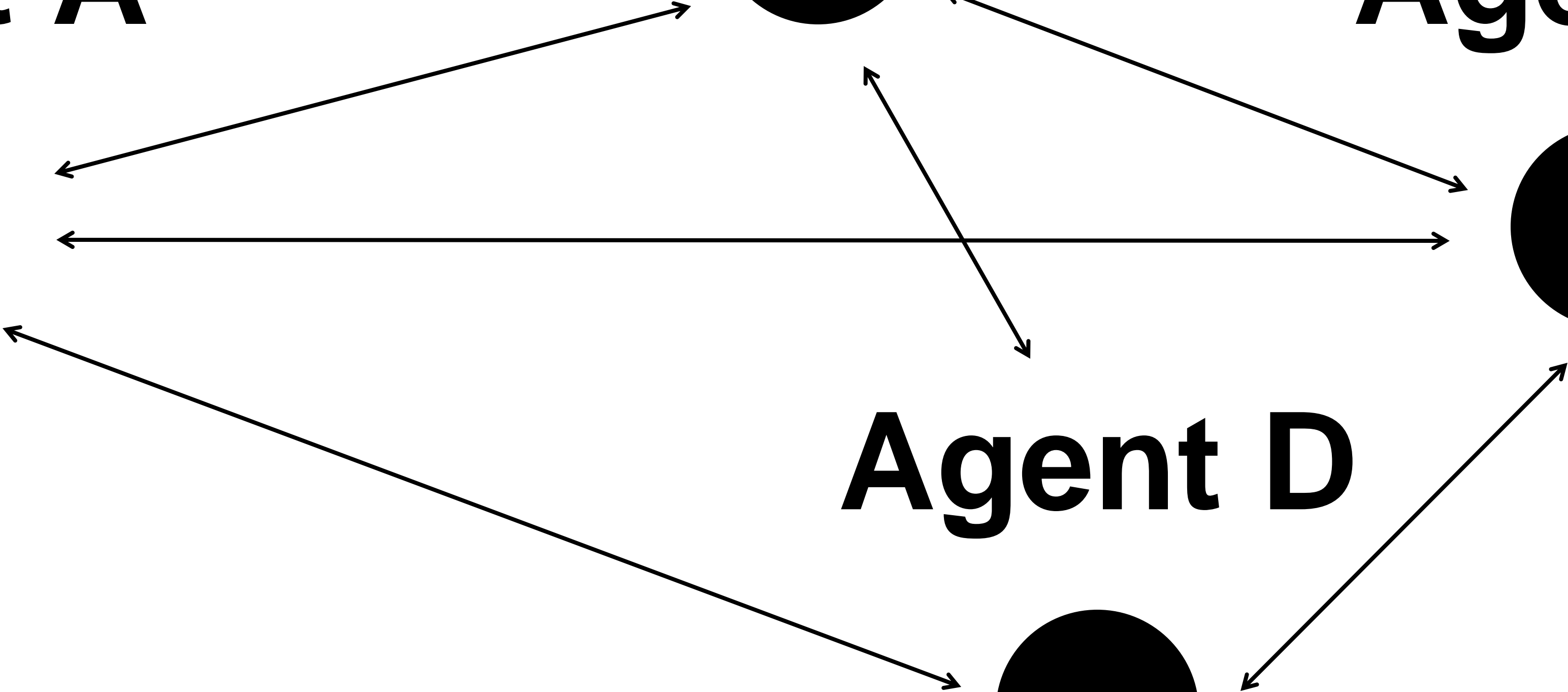
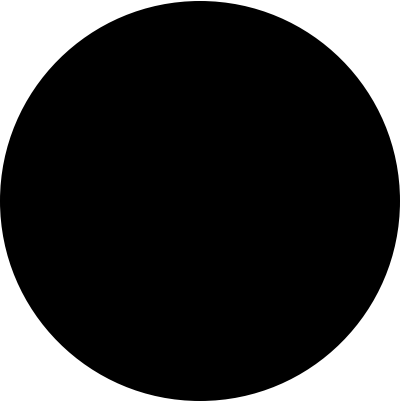

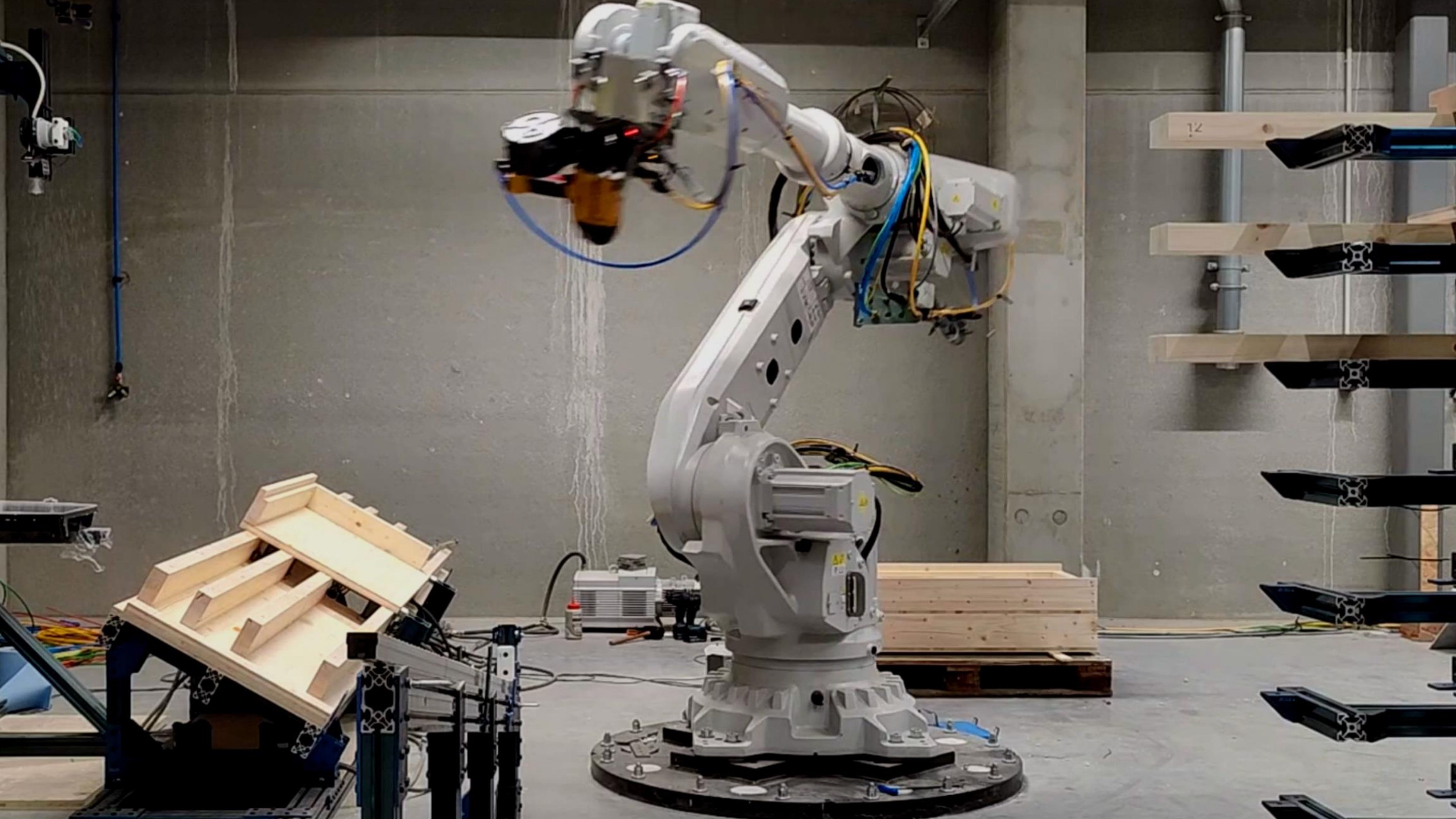

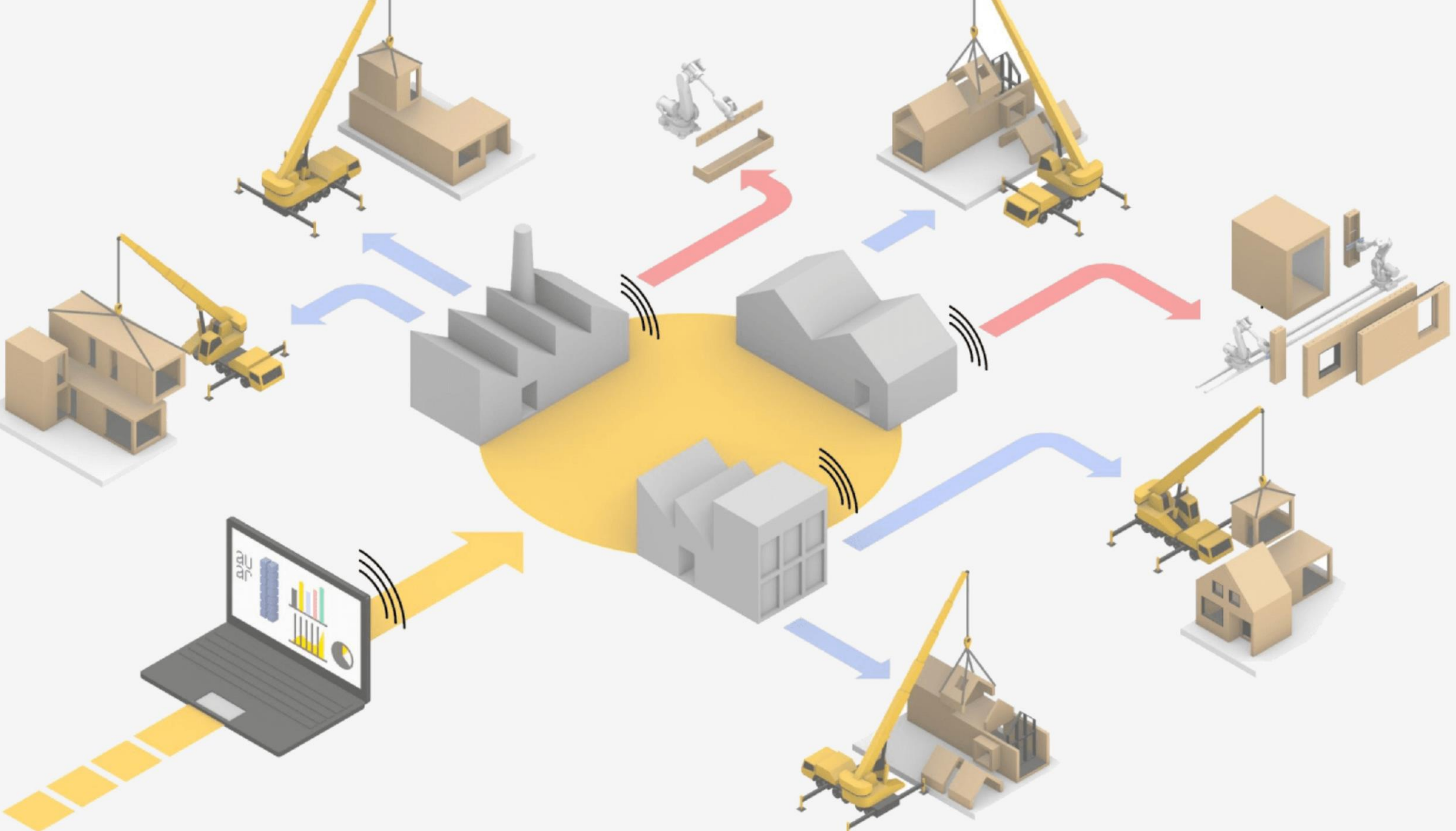

The Coming Wave

"Ciò che le persone faranno effettivamente con la tua invenzione, per quanto ben intenzionata, non può mai essere garantito."

Mustafa Suleyman

**I prossimi 5 anni si
concentreranno
principalmente su 2
temi:**

**I prossimi 5 anni si
concentreranno su due temi:**

- > Regolamentazioni,
governance ed etica**
- > Relazione Fisico / Digitale**

- 1. Regolamentazioni,
governance ed etica**
- 2. Autonomia nel
mondo fisico**

Supercraft
Perché super?

- 1. Contesto - Comprendere gli utenti, i materiali e l'ambiente circostante**
- 2. Progettazione - Assistere efficacemente**
- 3. Produzione - Ottimizzare il processo produttivo**

1_Contesto

**Sensori e feedback
Auto-miglioramento
Avanzamento dell'IoT**

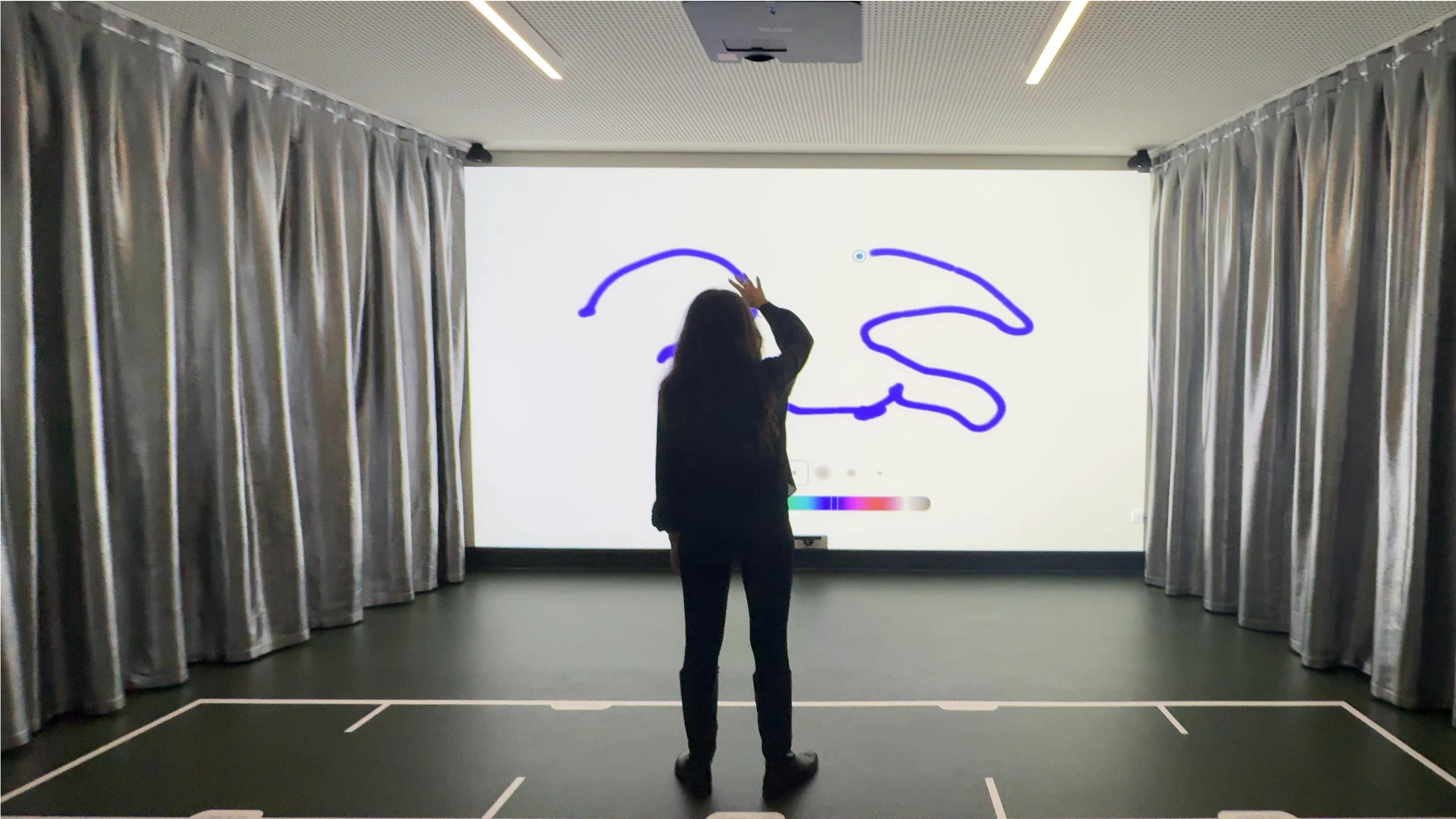

The image shows a computer monitor in a dark room, displaying a software interface. The interface is divided into several windows:

- Main Window:** A large window on the left side of the screen displays a complex network diagram with numerous nodes and connecting lines. The nodes are represented by small squares and rectangles, and the connections are thin lines. The background of this window is dark.
- CalibrationWindow:** A window in the upper right corner titled "CalibrationWindow" shows a camera view of a hallway with curtains. Below the camera view is a 3D model of a similar hallway, with a red and blue grid overlay. The numbers "2", "1", and "0" are visible on the grid.
- File Window:** A window in the lower right corner titled "File" shows a 3D model of a green object, possibly a plant or a piece of furniture, with a blue line representing a path or structure. Below the model is a color palette with various colors.

The monitor is mounted on a wall, and the room is dimly lit, with light coming from the screen and some ambient light from the ceiling. The ceiling has a grid pattern and a projector is visible at the top center.

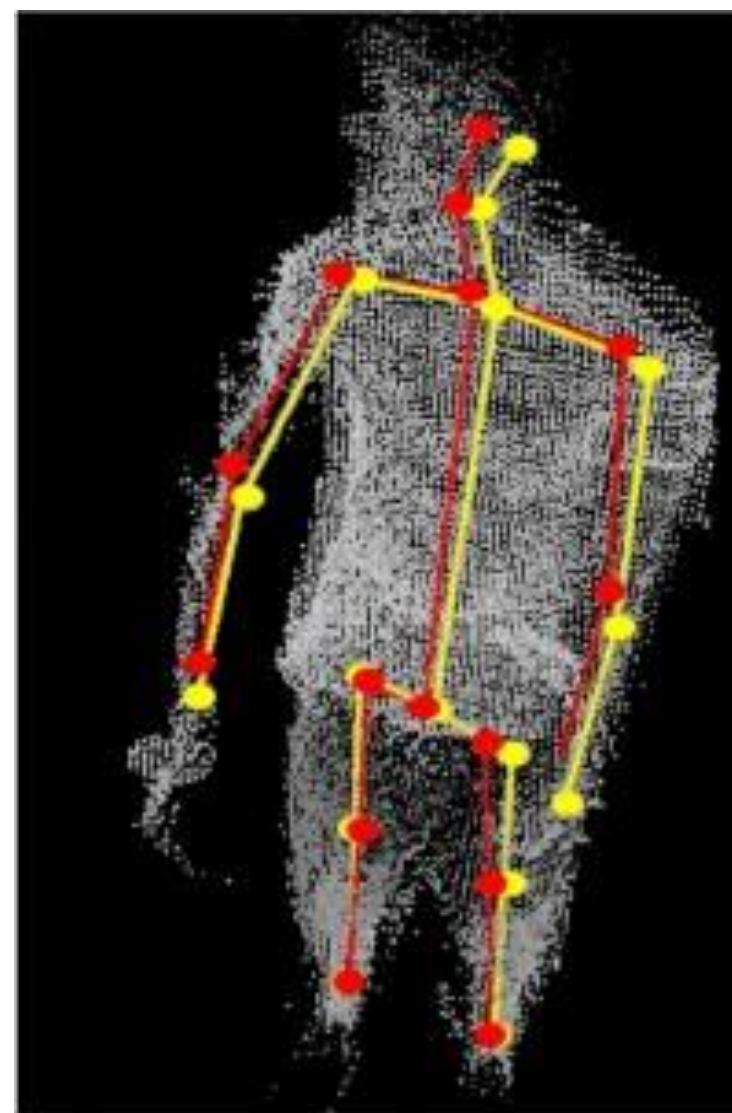
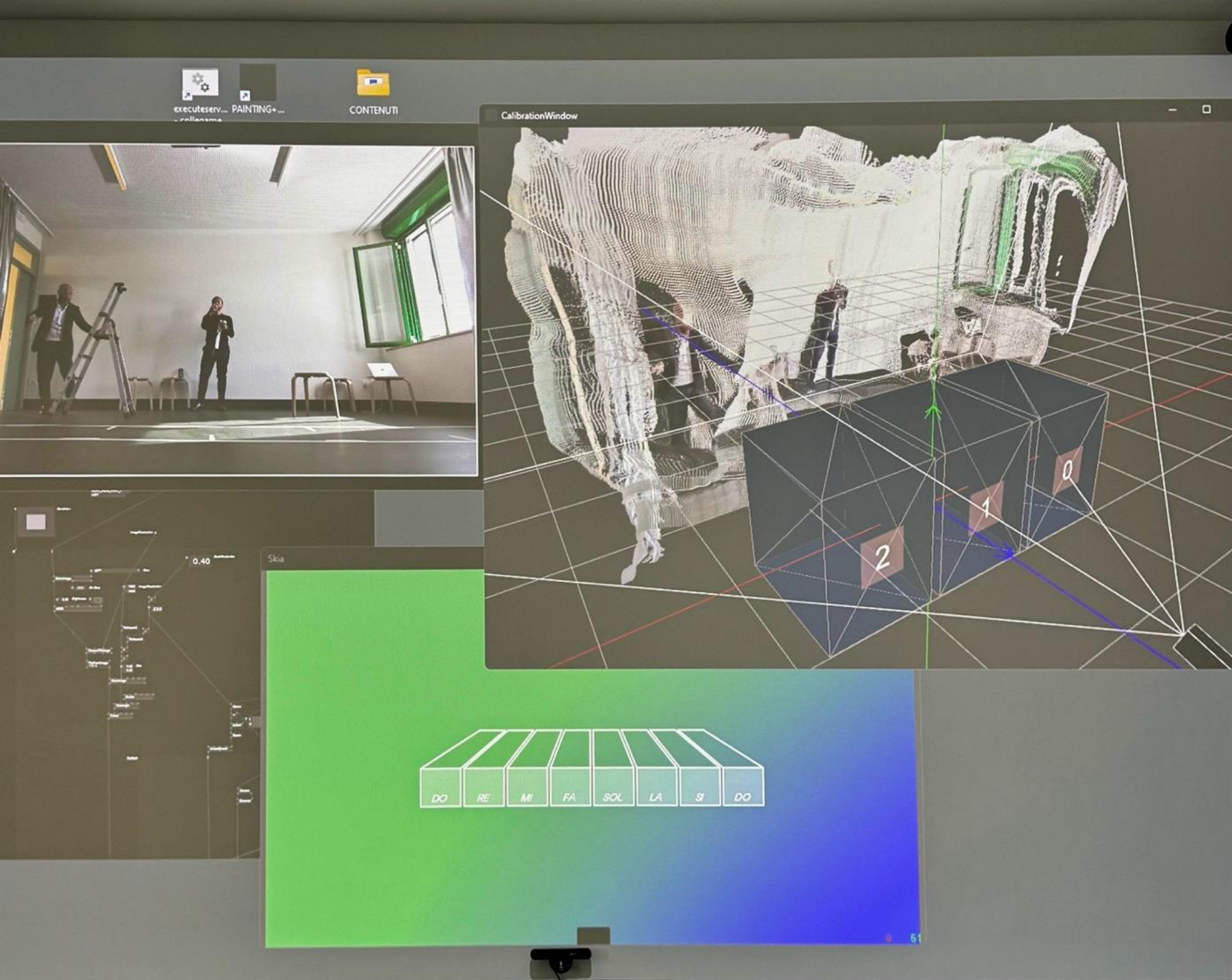

(a)

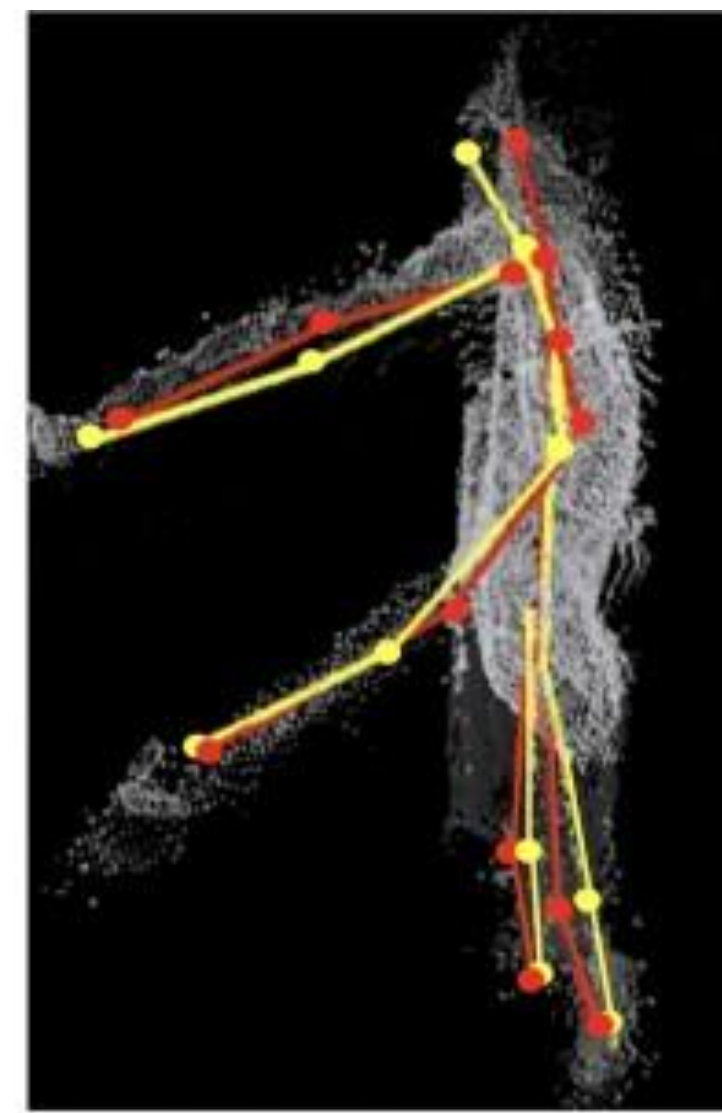

(b)



(c)



2_Progettazione

Design combinatorio
Design esplorativo
Design trasformativo





Generated design



Training data



Day 1

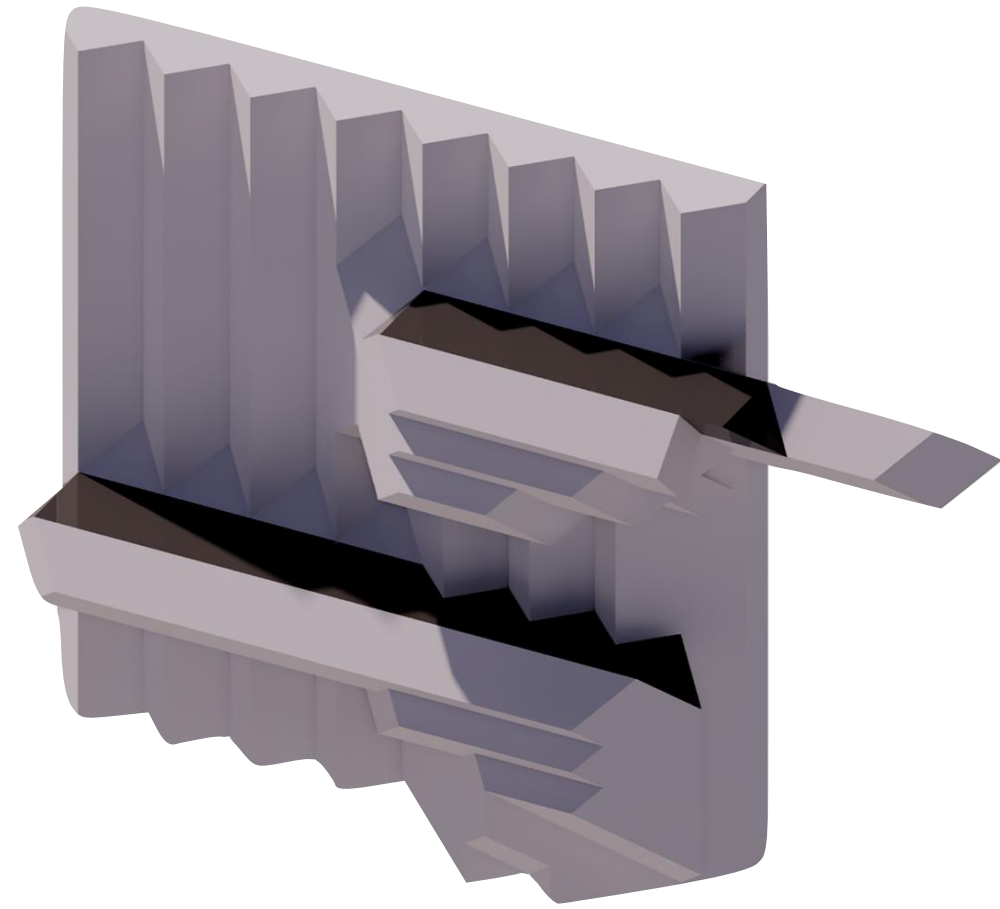

Day 100

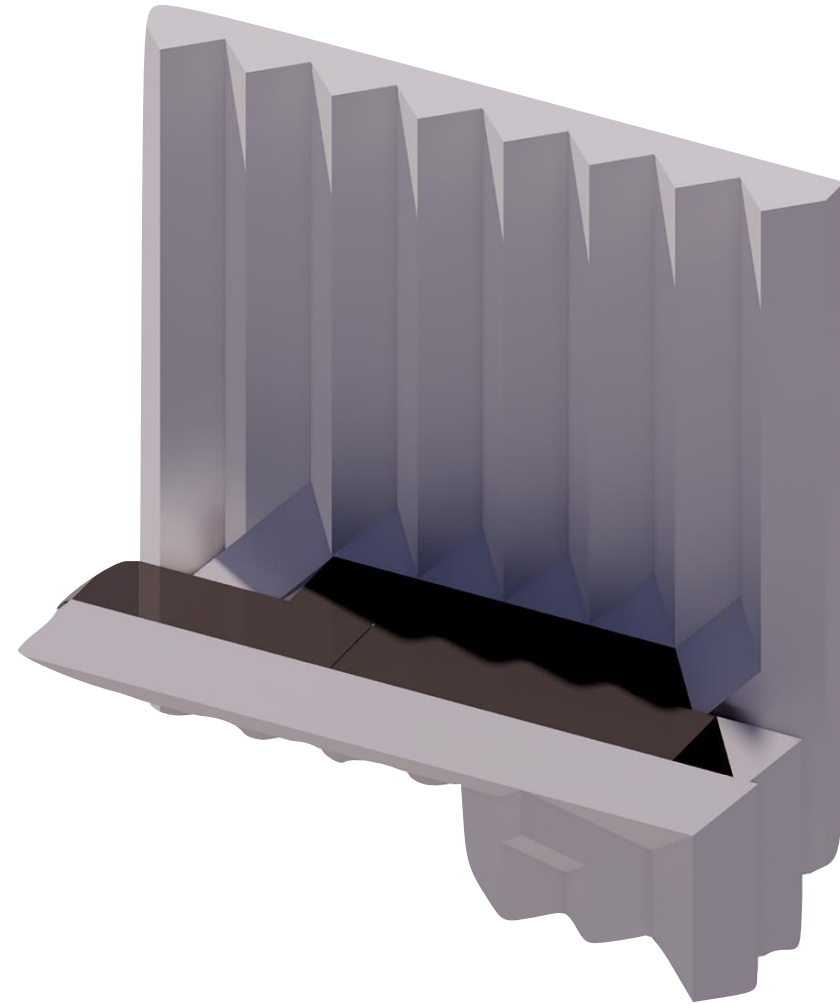

Day 400

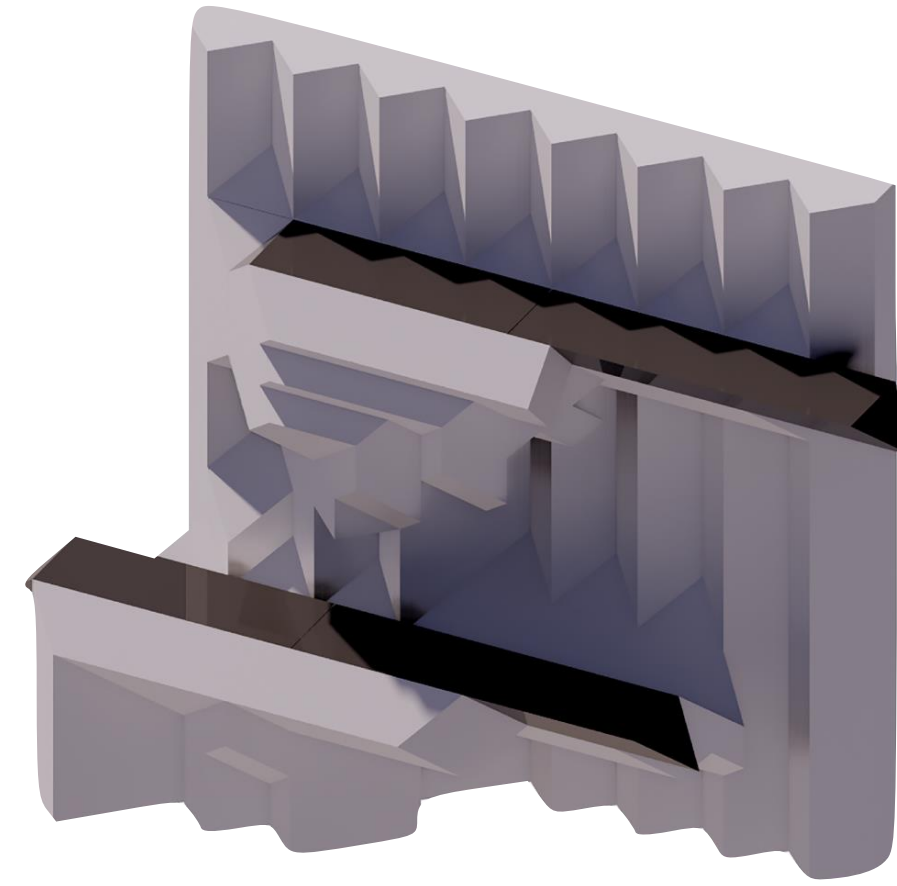

Day 1000

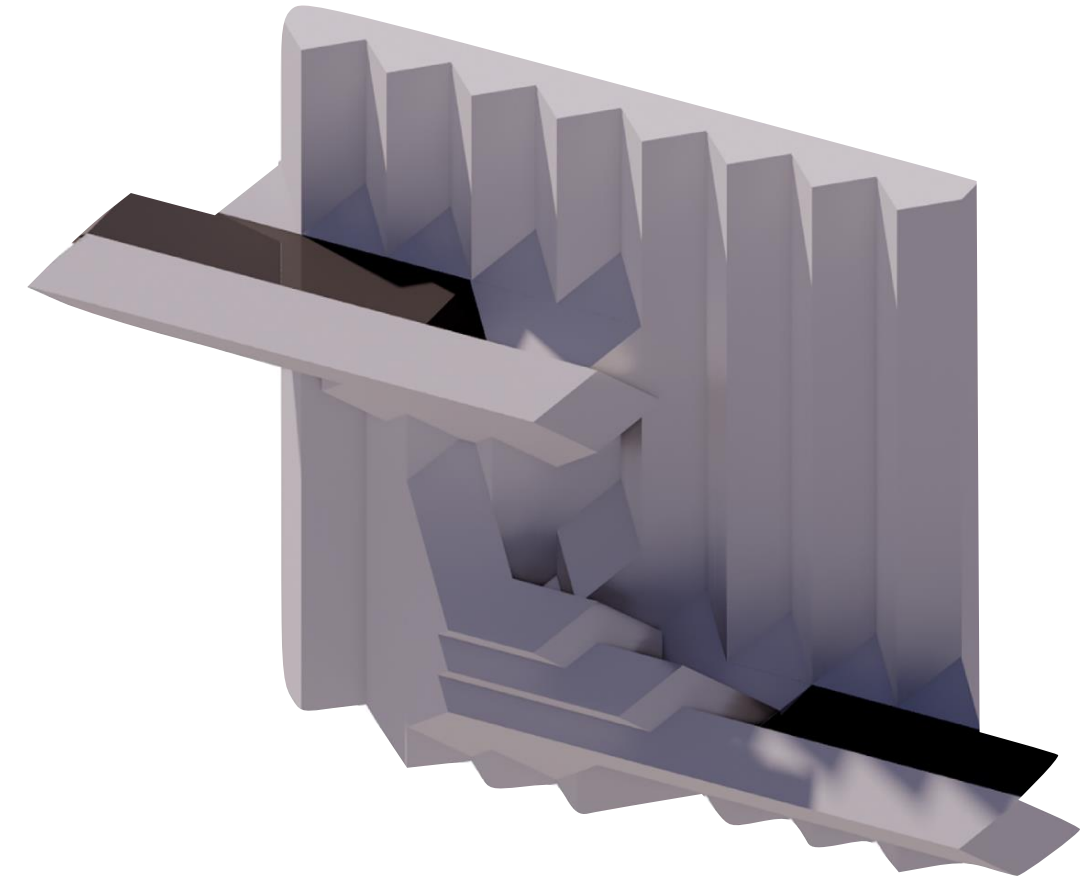

Furniture Inputs

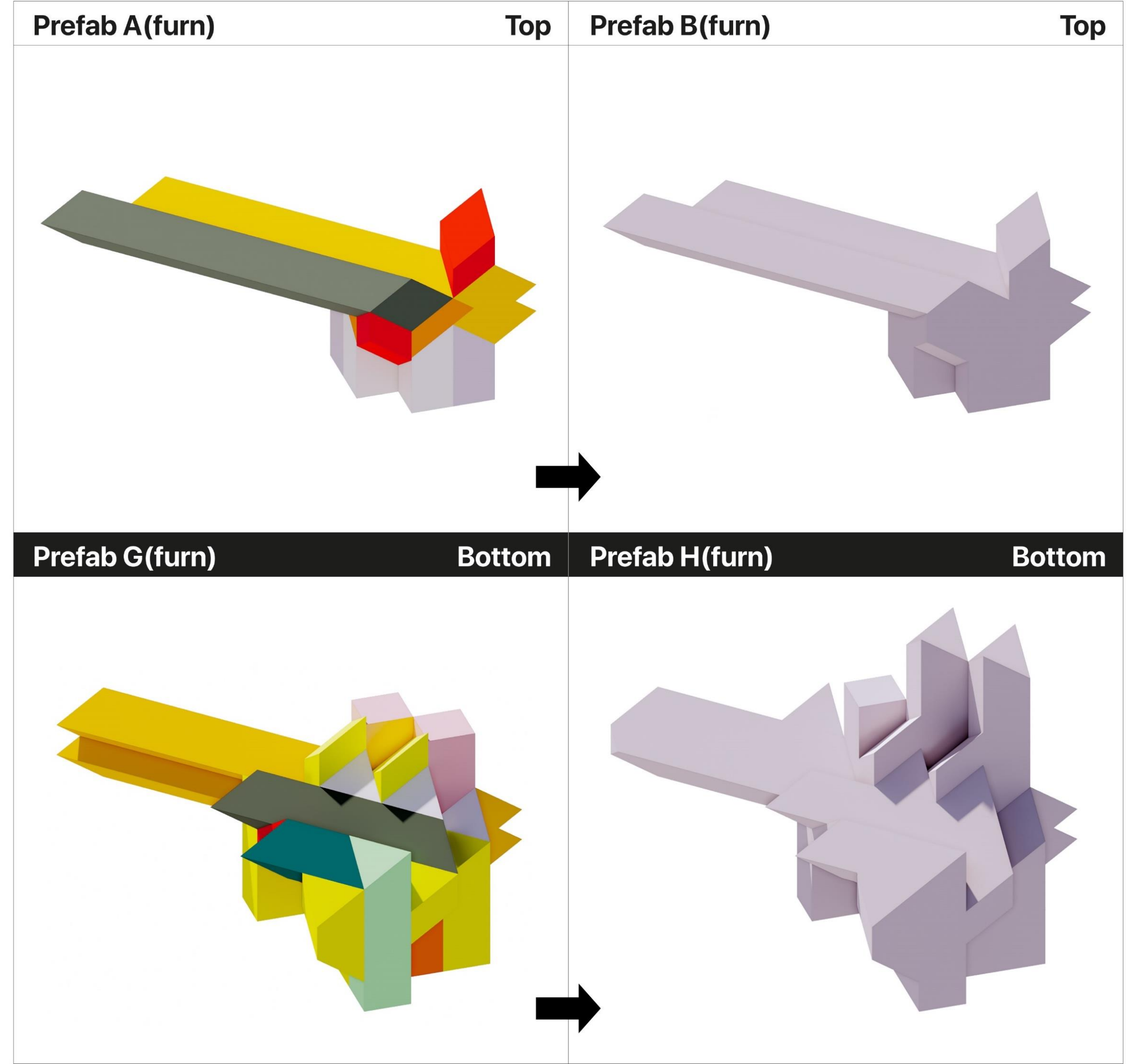
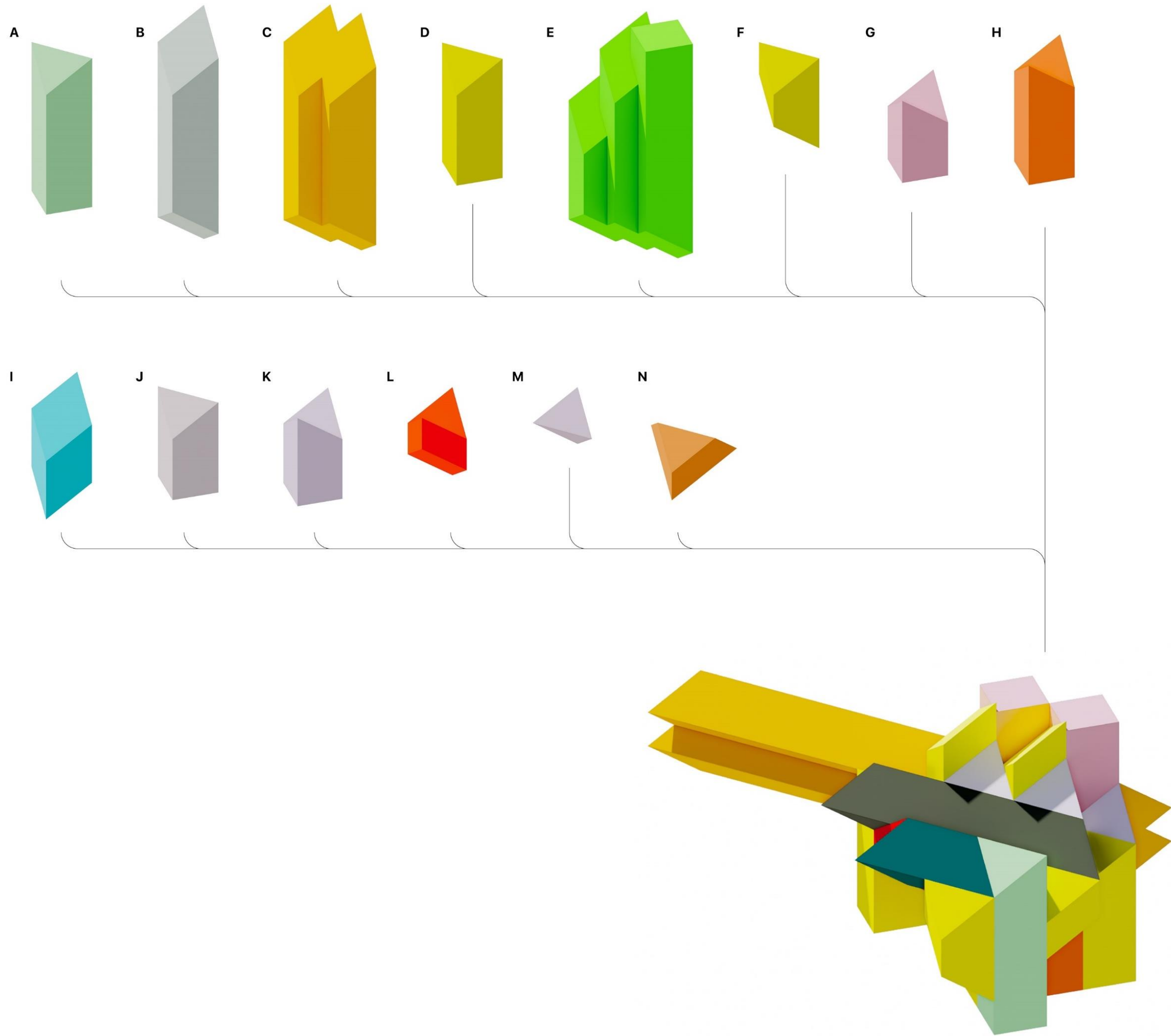



3_Produzione

**Prestazioni
Ottimizzazione
Co-pilota
Super-utenti**

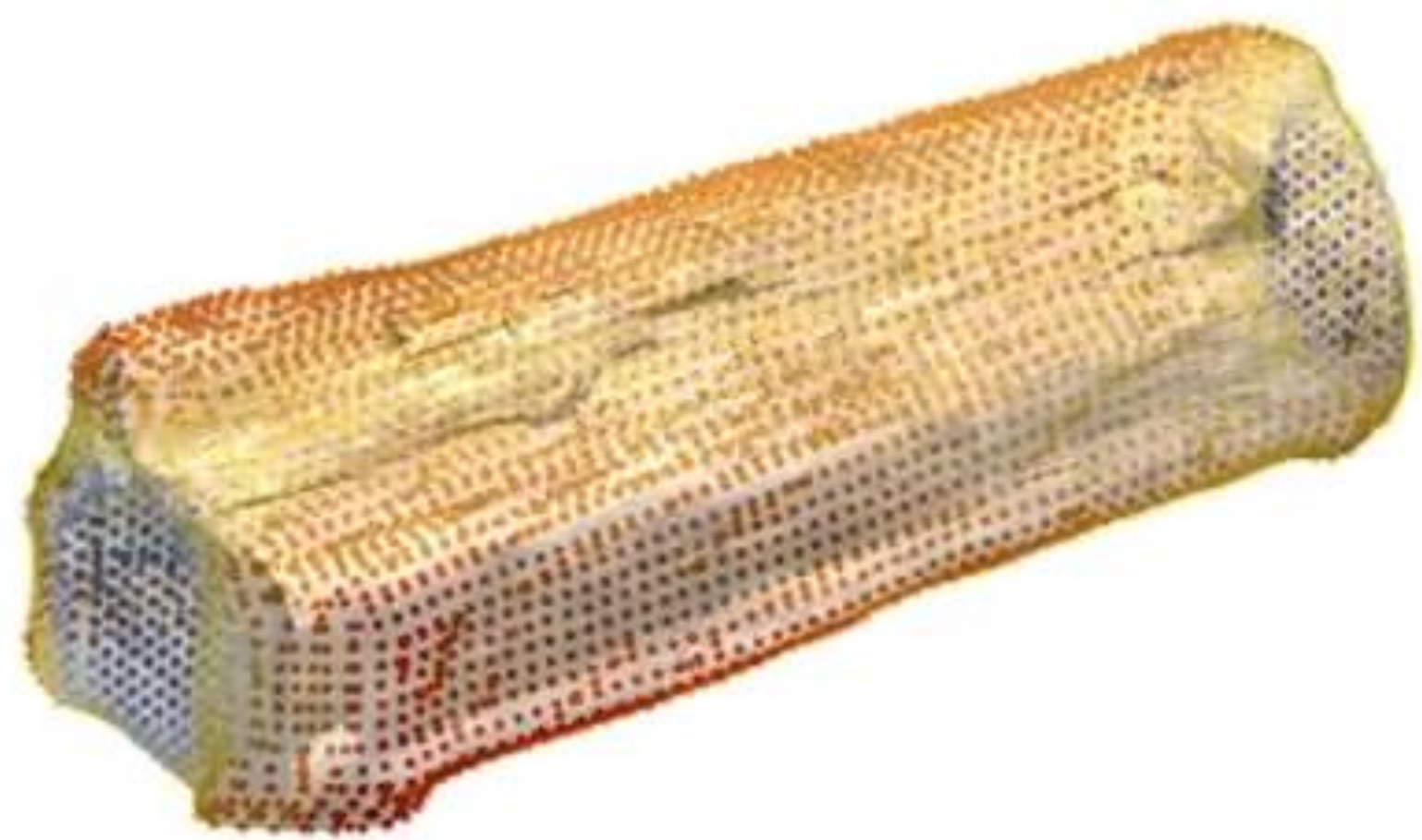



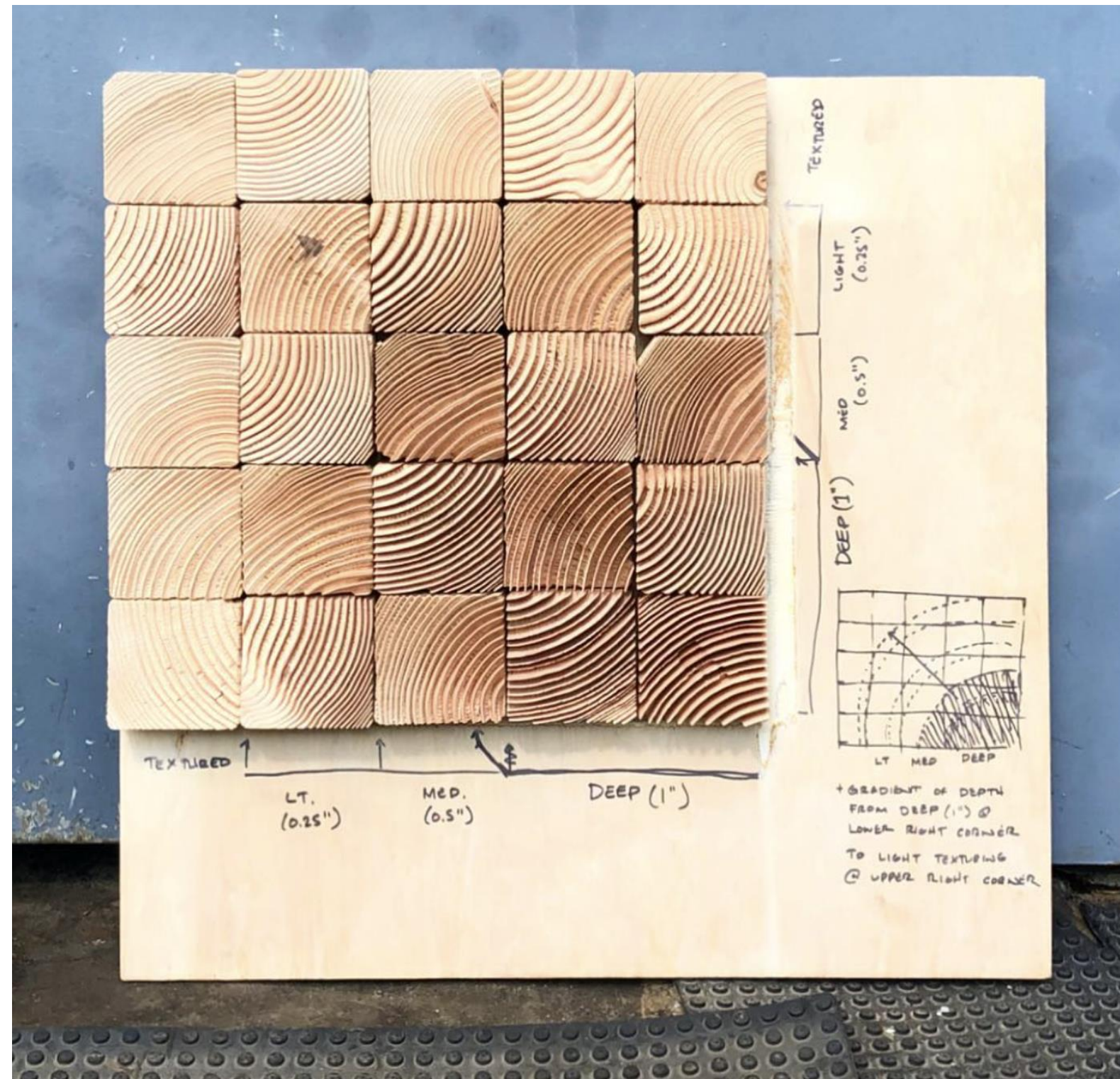



Purtroppo, dobbiamo ancora progettare software che funzioni... per tutto.



Error generating variations. Please try again.



"I want AI to do my laundry and dishes so that I can do art and writing, not for AI to do my art and writing so that I can do my laundry and dishes."

Author and videogame enthusiast **Joanna Maciejewska** nails it (although bathroom cleaning goes ahead of laundry and dishes)

"I'm sure..."

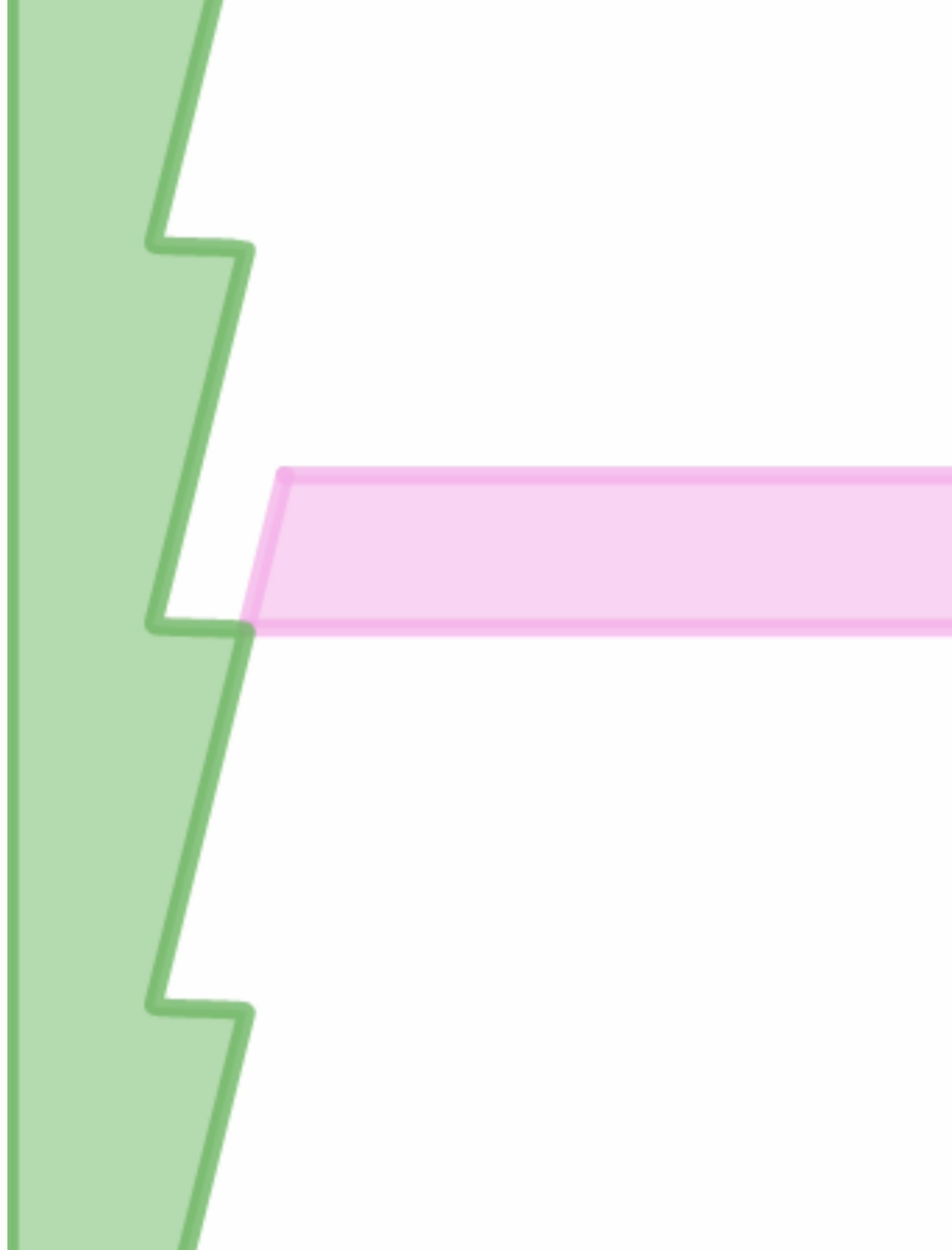

**“La tecnologia è la risposta,
ma qual è la domanda?”**

Cedric Price

Grazie